

Neles™ ball valve

Series M1, M2

Installation, maintenance and
operating instructions

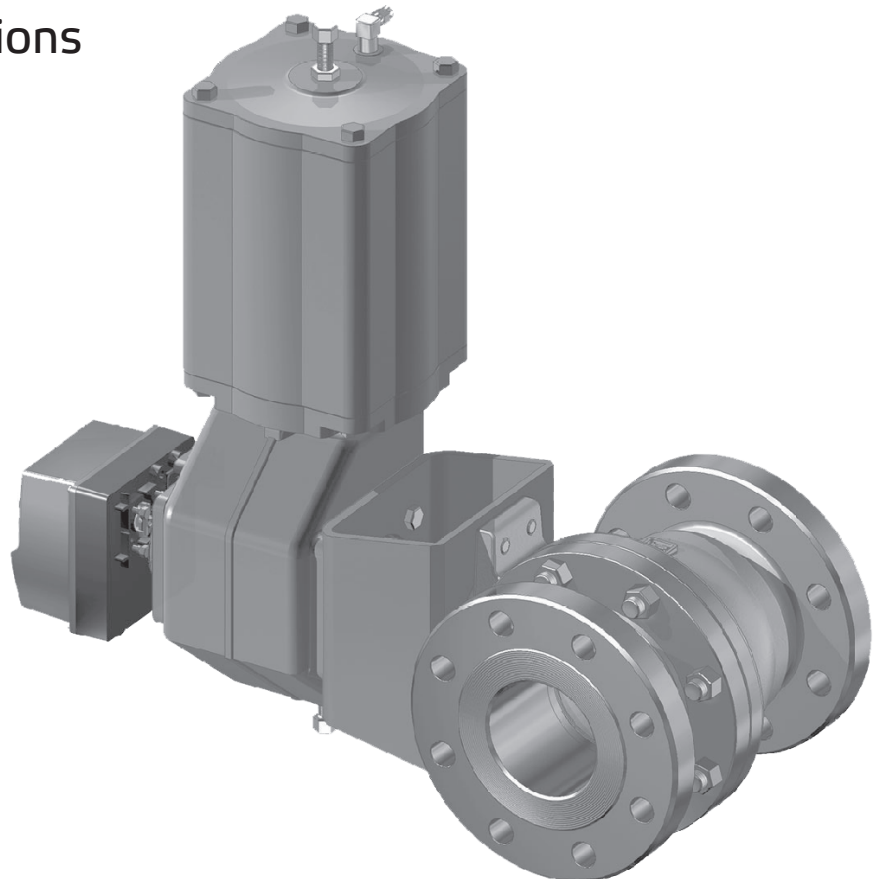

Table of contents

GENERAL	3	TESTING THE VALVE	13
Scope of the manual	3		
Valve construction	3	INSTALLING AND DETACHING THE ACTUATORS	13
Valve markings	4	General	13
Technical specifications	4	Installing the M actuator	13
Valve certifications	4	Installing the B1C actuator	13
CE marking	4	Installing the B1J actuator	14
Recycling and disposal	5	Detaching B series actuators	14
Safety precautions	5	Installing other manufacturer's actuators	14
Welding notes	5		
TRANSPORTATION, RECEPTION AND STORAGE	5	TROUBLE SHOOTING TABLE	15
INSTALLATION	6	TOOLS	15
General	6	ORDERING SPARE PARTS	15
Installing in the pipeline	6	EXPLODED VIEWS AND PARTS LISTS	16
Valve insulation	6	Sizes DN 25-40 / 1"-1.5", seat supported ball	16
Actuator	6	Sizes DN 50-200 / 2"-8", seat supported ball	17
COMMISSIONING	7	Sizes DN 250-300 / 10"-12", seat supported ball	18
MAINTENANCE	7	Sizes DN 250-400 / 10"-16", trunnion mounted ball	19
Maintenance general	7	Sizes DN 450-600 / 18"-24", trunnion mounted ball	20
Replacing the packing without removing the valve from the pipeline	7	DIMENSIONS AND WEIGHTS	21
Repairing a jammed or stiff valve without removing it from the pipeline	9	Seat supported valves	21
Detaching the actuator from the valve	9	Trunnion type valves	22
Removing the valve from the pipeline	9	Topwork assembly dimensions	24
Dismantling the valve	9	TYPE CODE	27
Checking the parts of a dismantled valve	10		
Replacing parts	10		
Reassembling the valve	10		

Subject to change without notice.

All trademarks are property of their respective owners.



This product meets the requirements set by the Customs Union of the Republic of Belarus, the Republic of Kazakhstan and the Russian Federation.

READ THESE INSTRUCTIONS FIRST!

These instructions provide information about safe handling and operation of the valve.

If you require additional assistance, please contact the manufacturer or manufacturer's representative.

SAVE THESE INSTRUCTIONS!

Addresses and phone numbers are printed on the back cover.

1. GENERAL

1.1 Scope of the manual

This manual provides the essential information on the use of M1 and M2 series ball valves. For further information on actuators and other instruments, which are covered only briefly, please refer to separate manuals on their installation, use and maintenance.

NOTE:

As the use of the valve is application specific, a number of factors should be taken into account when selecting the application. Therefore, some of the situations in which the valves are used are outside the scope of this manual.

If you are uncertain about use of the valve or its suitability for your intended purpose, please contact Valmet for more information.

1.2 Valve construction

M1 and M2 series valves are flanged ball valves. The valve is either metal or soft-seated. Valves have two-piece bodies with bolted body joints. In all models, the ball and the stem are separate parts and a stem blow-out is prevented by a shoulder machined on the stem (DN 250/10"-DN 600/24") or by a separate thrust ring /pin and retaining plates (DN 25/1"-DN 300/12").

In seat supported valves a spline driver transmitting the stem torque to the ball connects the stem with the ball. In DN 25/1" and DN 40/1.5" valves the stem is directly connected to the slot in the ball (no separate driver).

Seat supported valves are tight in both flow directions. Tightness is based on pipe pressure, i.e. the pressure differential over the valve forces the ball against the downstream seat. An arrow shows the flow direction in E-seated valves.

The construction of the valves may vary in accordance with customers' wishes. The construction details are indicated in the type code in the identification plate. For more information about the type code, see Section 12.

Seat supported valves are specially designed for demanding shut-off applications involving high operation cycles; with certain restrictions they can also be used in flow control applications.

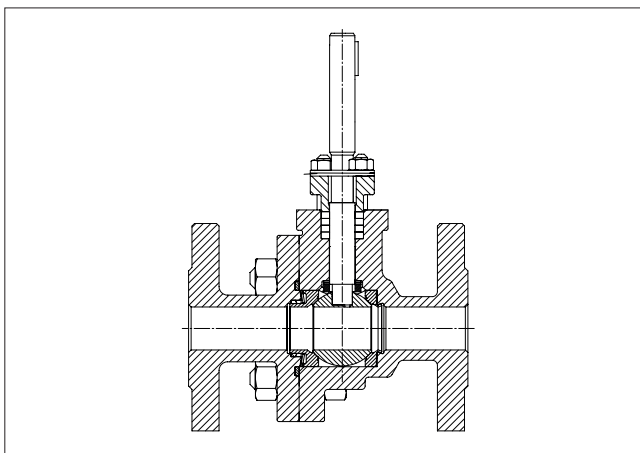

Fig. 1 Construction, sizes DN 25/1" to DN 40/1 1/2", seat supported ball

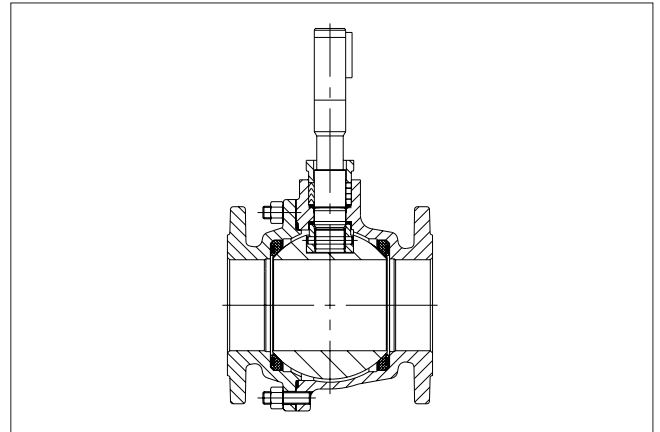

Fig. 2 Construction, sizes DN 50/1" to DN 200/8", seat supported ball

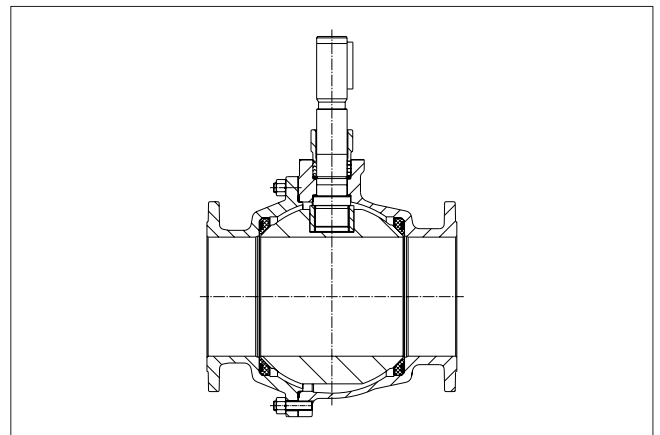

Fig. 3 Construction, sizes DN 250/10" and DN 300/12", seat supported ball

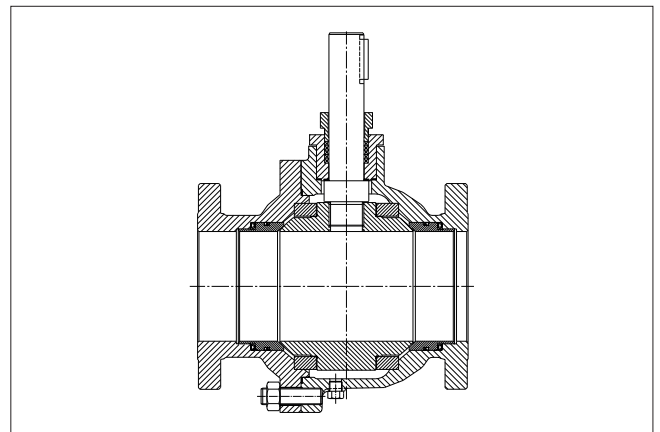

Fig. 4 Construction, sizes DN 250/10" to DN 600/24", trunnion mounted ball

In models with a trunnion mounted ball (Fig. 4) the stem splines transfer the rotating movement directly to the ball. The seats are spring loaded. A 2-seat valve is tight in both flow directions. The tightness-direction of a 1-seat valve is indicated with an arrow.

The sealing effect is the result of the springs forcing the seats against the ball, while the pipe pressure affects the seat upstream.

The valve is intended for on-off and control use. The construction of a supplied valve may differ depending on customer requirement.

The detailed construction is defined by the type coding on the ID-label. Type coding is explained in Section 12.

1.3 Valve markings

Body markings are cast on the body, Fig. 5.

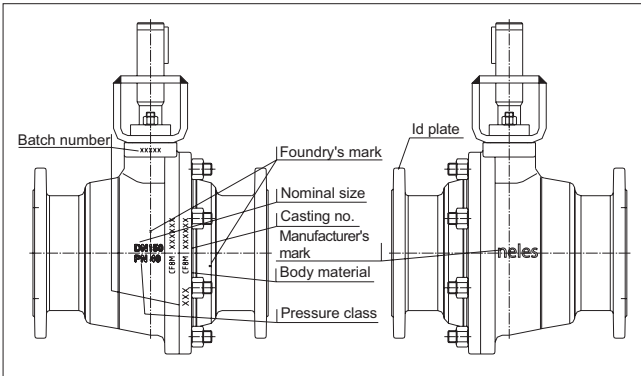

Fig. 5 Valve markings

The valve also has an identification plate attached to it, see Fig. 6.

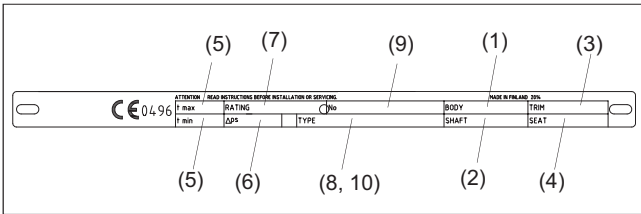

Fig. 6 Identification plate

Identification plate markings:

1. Body material
2. Shaft material
3. Trim material
4. Seat material
5. Maximum/minimum operating temperature
6. Maximum shut-off pressure differential
7. Pressure class
8. Type designation
9. Valve manufacturing parts list no.
10. Model

1.4 Technical specifications

Face-to-face length:	M1: ISO 5752 M2: ASME B16.10
Body rating:	M1: PN 10, 16, 25, 40 M2: ASME Class 150 and 300
Max. pressure differential:	see Figs. 8 and 9
Temperature range:	see Fig. 7
Flow direction:	indicated by an arrow on the body Trunnion mounted: 1-seated (tight direction) Seat supported: E-seated
Dimensions:	see Section 11
Weights:	see Section 11

1.5 Valve certifications

A tightness certificate can be granted on request.

1.6 CE marking

The valve meets the requirements of the European Directive 2014/68/EU relating to pressure equipment, and has been marked according to the Directive.

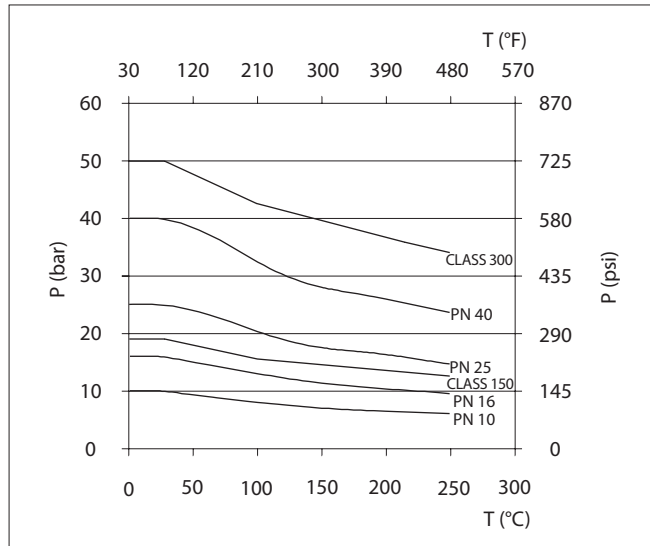

Fig. 7 Pressure/temperature curves of valve body CF8M and CG8M

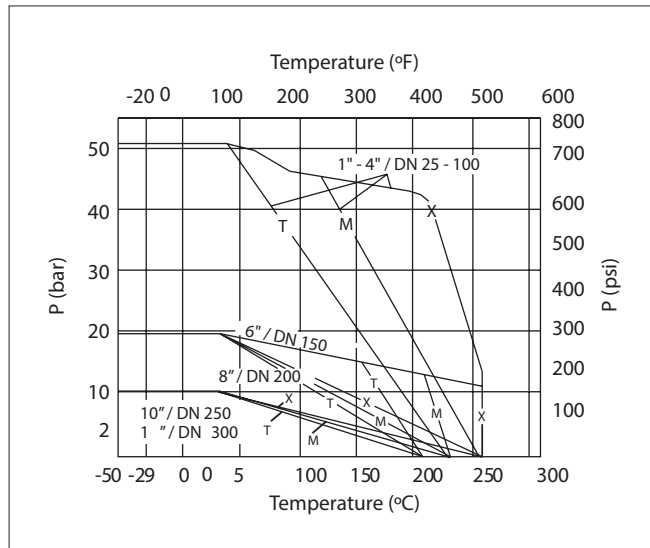

Fig. 8 Pressure differentials permitted in operations (soft-seated valves)

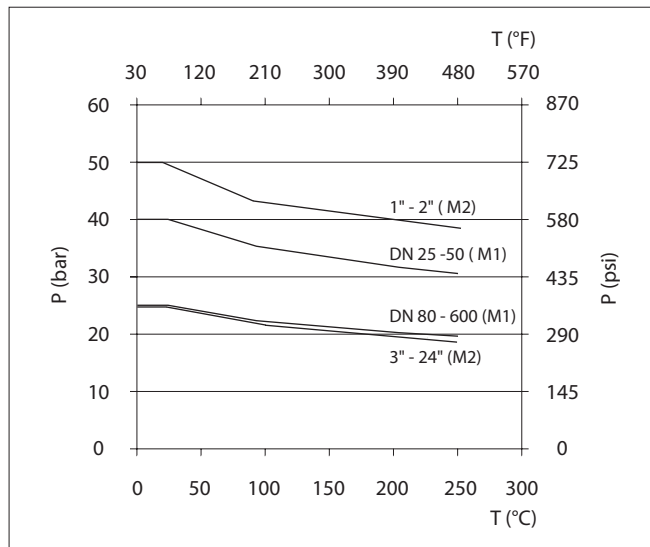

Fig. 9 Pressure differentials permitted in operations (metal-seated valves)

1.7 Recycling and disposal

Most valve parts can be recycled if sorted according to material.

Most parts have material marking. A material list is supplied with the valve. In addition, separate recycling and disposal instructions are available from the manufacturer.

A valve can also be returned to the manufacturer for recycling and disposal against a fee.

1.8 Safety precautions

CAUTION:

Do not exceed the valve performance limitations!

Exceeding the limitations marked on the valve may cause damage and lead to uncontrolled pressure release. Damage or personal injury may result.

CAUTION:

Do not dismantle the valve or remove it from the pipeline while the valve is pressurized!

Dismantling or removing a pressurized valve will result in uncontrolled pressure release. Always isolate the relevant part of the pipeline, release the pressure from the valve and remove the medium before dismantling the valve.

Be aware of the type of medium involved. Protect yourself and the environment from any harmful or poisonous substances. Make sure that no medium can enter the pipeline during valve maintenance.

Failure to do this may result in damage or personal injury.

CAUTION:

Beware of the ball movement!

Keep hands, other parts of the body, tools and other objects out of the open flow port. Leave no foreign objects inside the pipeline. When the valve is actuated, the ball functions as a cutting device. Close and detach the actuator pressure supply pipeline for valve maintenance. Failure to do this may result in damage or personal injury.

CAUTION:

Protect yourself from noise!

The valve may produce noise in the pipeline. The noise level depends on the application. It can be measured or calculated using the Neles Nelprof software. Observe the relevant work environment regulations on noise emission.

CAUTION:

Beware of extreme temperatures!

The valve body may be very cold or very hot during use. Protect people against cold injuries or burns.

CAUTION:

When handling the valve or the valve package, take its weight into account!

Never lift the valve or valve package by the actuator, positioner, limit switch or their piping.

Place the lifting ropes securely around the valve body (see Fig. 10). Damage or personal injury may result from falling parts.

CAUTION:

Potential electrostatic charging hazard. Ensure the protection in the process.

1.9 Welding notes

WARNING:

Welding and/or grinding stainless steel and other alloys containing chromium metal may cause the release of hexavalent chromium. Hexavalent chromium(VI) or Cr(VI), is known to cause cancer. Be sure to use all appropriate personal protective equipment (PPE) when welding metals containing chromium.

NOTE:

A qualified welder must do the installation welding. The welder and welding procedure should be qualified in accordance with the ASME Boiler and Pressure Vessel Code Section IX or other applicable regulation.

CAUTION:

To prevent damage to the seat and seals, do not allow the temperature of the seat and body seal area to exceed 94 °C (200 °F). It is recommended that thermal chocks be used to check the temperature in these areas during welding.

CAUTION:

Ensure that any weld splatter does not fall onto the valve closing members eg. ball or seats. This may damage critical seating surfaces and cause leaks.

2. TRANSPORTATION, RECEPTION AND STORAGE

Check the valve and the accompanying device for any damage that may have occurred during transport.

Store the valve carefully. We recommend storing indoors in a dry place.

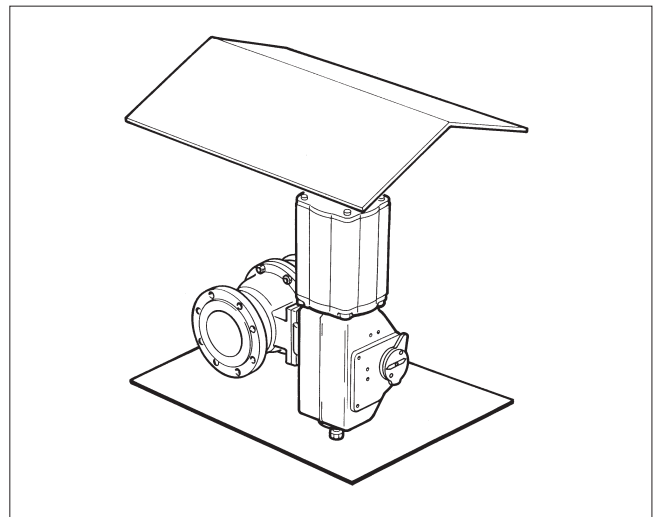

Fig. 10 Storing the valve

Do not remove the flow port protectors until installing the valve.

Move the valve to its intended location just before installation.

The valve is usually delivered in the open position.

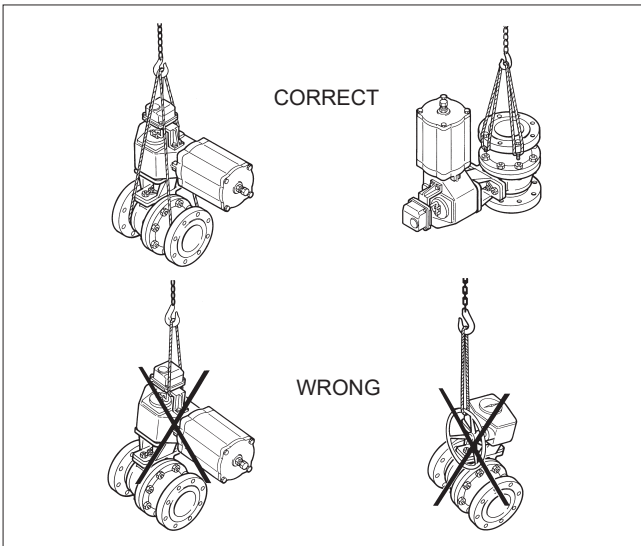

Fig. 11 Lifting the valve

3. INSTALLATION

3.1 General

Remove the flow bore protectors and check that the valve is clean inside. Clean the valve if necessary.

3.2 Installing in the pipeline

CAUTION:

When handling the valve or the valve package as a whole, bear in mind the weight of the valve or the entire package!

Flush the pipeline carefully before installing the valve. Make sure the valve is entirely open when flushing. Foreign particles, such as sand or pieces of welding electrode, will damage the ball and seats.

Remove the flow port protectors and check that the valve is clean inside. Place the valve in the open position.

CAUTION:

On the NPS12" pressure class 300 Short Pattern in seat supported M2 series, the ball protrudes from flange, when ball is in closed position. Failure to install or remove the valve in the open position may result to damage to ball.

NOTE:

Use screws, nuts, bolts and gaskets equivalent to the fastenings used elsewhere in the pipeline. Center the flange gaskets carefully when fitting the valve between flanges.

NOTE:

Do not attempt to correct pipeline misalignment by means of flange bolting.

The valve may be installed in any position and offers tightness in both directions, except the 1-seat valves with trunnion mounted ball. However we do not recommend installing the valve with the actuator on the underneath side because dirt in the pipeline may then enter the body cavity and damage the gland packing. The position to be avoided is shown in Fig. 12.

It may be necessary to firmly support the pipeline in order to protect the valve from excess stress. Sufficient support will also reduce pipeline vibration and thus ensures proper functioning of the positioner.

To facilitate servicing, it is preferable that the valve be supported by the body, using pipe clamps and supports. Do not fasten supports to the flange bolting or to the actuator, see Fig. 13.

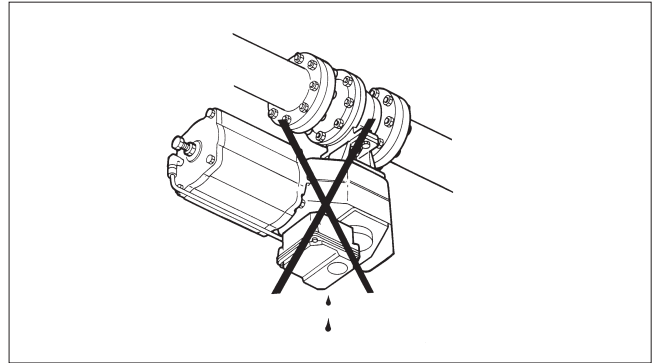

Fig. 12 Avoid this mounting position

3.3 Valve insulation

If necessary, the valve may be insulated. Insulation must not continue above the upper level of the valve body, see Figure 13.

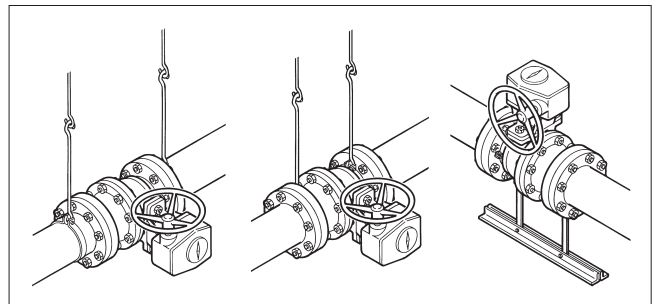

Fig. 13 Supporting the valve

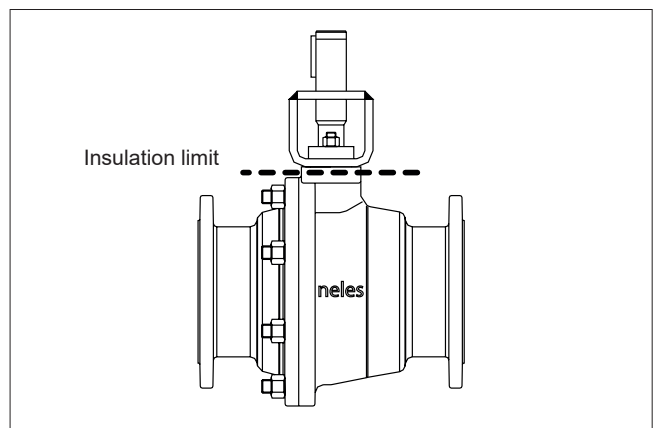

Fig. 14 Insulation of the valve

3.4 Actuator

NOTE:

When installing the actuator on the valve, make sure that the valve package functions properly. Detailed information on actuator installation is given in Section 6 or in the separate actuator instructions.

The valve open/closed position is indicated as follows:

- by an indicator on the actuator or
- by a groove at the end of the ball stem (parallel to the ball flow opening).

If there is any uncertainty about the indicator, check the ball position by the groove.

The actuator should be installed in a manner that allows plenty of room for its removal.

The upright position is recommended for the actuator cylinder.

The actuator must not touch the pipeline, because pipeline vibration may interfere with its operation.

In certain cases it may be considered advantageous to provide additional support to the actuator. These cases will normally be associated with large actuators, extended stems, or where severe vibration is present. Please contact Valmet for advice.

4. COMMISSIONING

Ensure that there is no dirt or foreign objects left inside the valve or pipeline. Flush the pipeline carefully. Make sure that the valve is entirely open when flushing.

Ensure that all nuts, pipings, and cables are properly fastened.

Check that the actuator, positioner, and switch are correctly adjusted. Actuator adjustment is explained in Section 6. To adjust the accompanying device refer to the separate control equipment instruction manuals.

5. MAINTENANCE

5.1 Maintenance general

CAUTION:

Observe the safety precautions mentioned in Section 1.8 before maintenance!

CAUTION:

When handling the valve or the valve package as a whole, bear in mind the weight of the valve or the entire package.

Although Neles valves are designed to work under severe conditions, proper preventative maintenance can significantly help to prevent unplanned downtime and in real terms reduce the total cost of ownership. Valmet recommends inspecting the valves at least every five (5) years.

The inspection and maintenance interval depends on the actual application and process condition.

The inspection and maintenance intervals can be specified together with your local Valmet experts. During this periodic inspection the parts detailed in the Spare Part Set should be replaced. Time in storage should be included in the inspection interval.

Maintenance can be performed as presented below. For maintenance assistance, please contact your local Valmet office. The part numbers in the text refer to the exploded view and to the parts list in Section 10, unless otherwise stated.

NOTE:

When sending goods to the manufacturer for repair, do not disassemble them. Clean the valve carefully and flush the valve internals. For safety reasons, inform the manufacturer of the type of medium used in the valve (include material safety datasheets (MSDS)).

NOTE:

In order to ensure safe and effective operation, always use original spare parts to make sure that the valve functions as intended.

NOTE:

For safety reasons, replace pressure retaining bolting if the threads are damaged, have been heated, stretched or corroded.

5.2 Replacing the packing without removing the valve from the pipeline

CAUTION:

Do not remove or dismantle a pressurized valve!

CAUTION:

For safety reasons the retaining plates (42) MUST always be installed as shown in 10.1, 10.2 and 10.3 (DN 25-300/1"-12")!

Because of pressure, the V-ring packing does not require any regular tightening as any increase in pressure will also increase tightness. Compression by the gland provides the necessary tightness in the packing.

Replace the packing (69) if tightening of the hexagon nuts (18) does not stop leakage. V-ring packing can be damaged by the use of excessive force and should therefore be tightened with care.

- Make sure that there is no pressure in the valve.
- Detach the actuator, the bracket and the key (10).
- See also Section 4.4.
- Remove the nuts (18) and the retaining plates (42).
- Remove the gland (9).
- Remove the packing rings (69) from around the stem using a knife or other pointed instrument. Make sure that there is no damage to the stem or the counterbore. Please note that the thrust ring (67) may come off as you remove the packing. It should be placed back in its position before installing the new packing (thrust rings are used in 2"-8" valves). Please note that in sizes 2"-8" the conical face of the thrust ring should point towards the valve.

CAUTION:

Do not remove the locking wire (51) located under the thrust ring (67)!

- Clean the counterbore, if necessary.
- Place the new packing rings (69) around the stem (5) and in the counterbore, e.g. using the gland (9). See Figure 15 for correct position of the packing

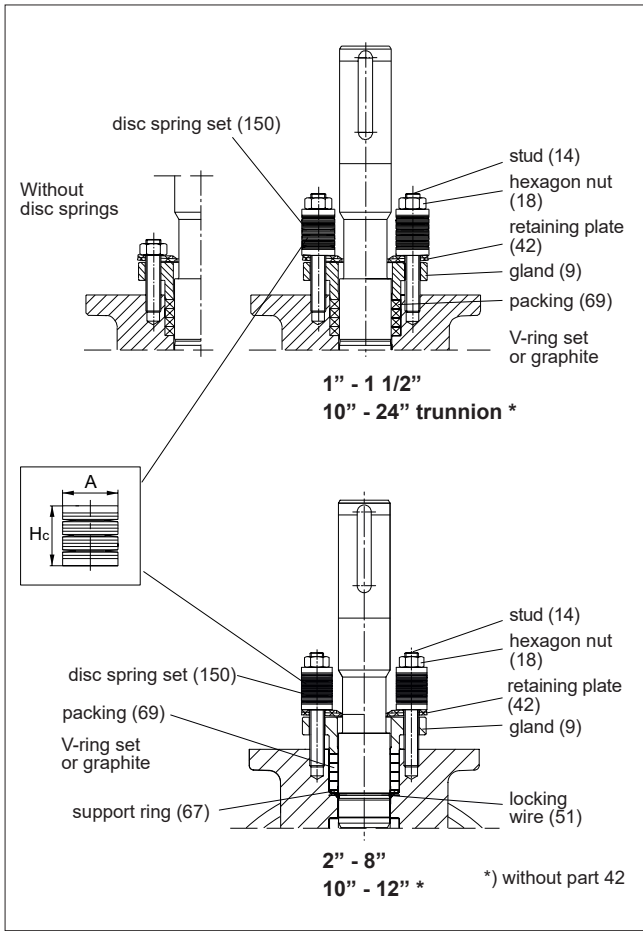

- Fasten the gland (9) (and if working on a DN 25-200/1"-8" valve, the retaining plates (42)), place the nuts (18) on the studs (14) and tighten as shown in Table 1. Select correct packing type (PTFE/Graphite) and packing construction (live loaded or not).

In case of leakage through the packing of a pressurized valve, carefully tighten the nuts until the leakage stops.

Fig. 15 Packing

Table 1 Tightening of gland packing

	Valve size		Shaft dia	Spring dimensions (free)		PTFE V-ring		Graphite	
						Disc spring	Nut	Disc spring	Nut
						Compression, mm	T _t , Nm	Compression, mm	T _t , Nm
Seat supported	25	01	15	20	22	0.8	3	1.7	5
	40	015	20	20	22	1.0	3	1.8	6
	50	02	25	25	30.5	1.1	7	2.1	14
	65		25	25	30.5	1.1	7	2.1	14
	80	03	25	25	30.5	1.1	7	2.1	14
	100	04	35	25	30.5	1.4	9	2.3	15
	125		35	25	30.5	1.4	9	2.3	15
	150	06	45	35.5	41	1.9	20	3.4	35
	200	08	55	35.5	41	2.2	23	3.6	38
	250	10	65	50	59	1.5	38	3.2	80
Trunnion	300	12	75	50	59	1.7	43	3.7	91
	250	10	55	35.5	41	2.2	23	3.6	38
	300	12	55	35.5	41	2.2	23	3.6	38
	350	14	75	50	59	1.7	43	3.7	91
	400	16	85	50	59	1.9	48	4.1	102
	450	18	85			1.5	54	3.0	108
	500	20	85			1.5	54	3.0	108
	500	20	95			2.2	126	4.4	252
600	24	95			2.2	126	4.4	252	
600	24	120			3.5	156	7.0	311	

5.3 Repairing a jammed or stiff valve without removing it from the pipeline

Jamming or stiff function at the valve may be caused by a flow medium clogging the seat (7) and the ball (3). The ball and the seats can be cleaned without removing the valve from the pipeline by turning the ball to a partly open position and flushing the pipes. If this does not help, follow the instructions below.

5.4 Detaching the actuator from the valve

CAUTION:

When handling the valve package, remember its weight!

NOTE:

To ensure proper reassembly, observe the position of the actuator and positioner/limit switch with respect to the valve before detaching the actuator.

It is generally most convenient to detach the actuator and its auxiliary devices before removing the valve from the pipeline. If the valve package is small or if it is difficult to access, it may be more practical to remove the entire package at the same time.

See Section 6 for details of detaching actuators.

5.5 Removing the valve from the pipeline

CAUTION:

Do not remove or dismantle a pressurized valve!

Make sure that the pipeline is empty and unpressurized and that there is no medium flowing to the pipeline while the valve is being serviced.

Carefully attach the ropes, loosen the pipe flange screws and lift the valve using the ropes. Make sure that you lift the valve correctly. See also Figure 10.

5.6 Dismantling the valve

Sizes DN 25-300/1"-12", seat supported

- Place the valve so that the body's hexagon nuts (16) / Body cap (2) point upwards. Use a surface that does not damage the flanges.
- Mark the body halves for correct orientation during reassembly.
- Loosen the gland nuts (18).
- Turn the ball to the closed position.
- Loosen the body's hexagon nuts (16).
- Remove the body cap (2) from the valve. Should the ball seat (7) not stay on the body cap, keep it from falling while you are lifting it out by putting your fingers under the body cap (small sizes) or in the flow bore (large sizes). Watch out for your hand! Lower the body cap onto the surface in a standing position, i.e. onto its flange (see Figure 16).

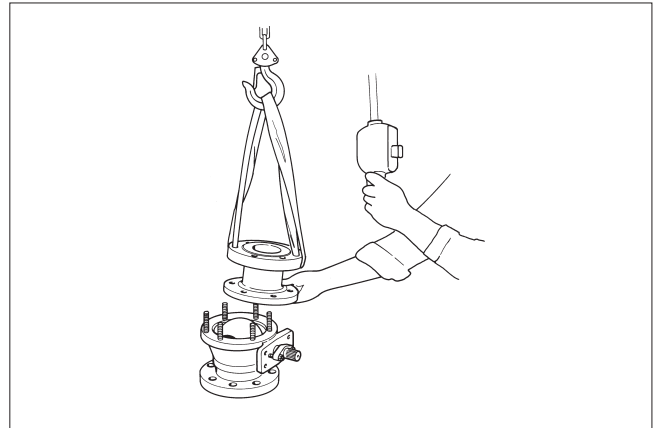

Fig. 16 Lifting a body cap

- Remove the seat (7) from the body cap making sure that it is not damaged during the operation. If the seat is of a locked type, use a special tool which can be ordered from the manufacturer (see Figure 17 and Section 8 'Tools').

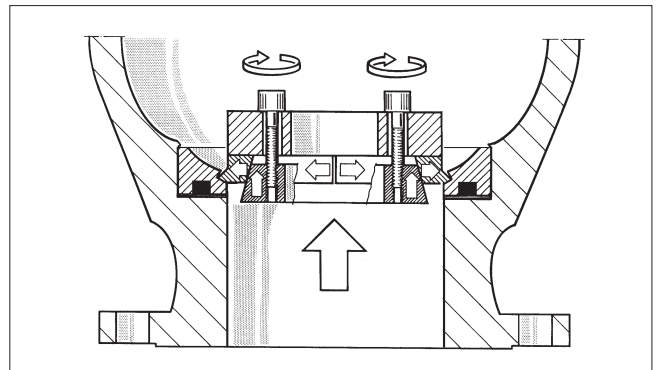

Fig. 17 Removing a locked seat

- Remove the ball (3) from the body (1) by gripping the edges of the flow bore (small sizes) or by passing a rope through the bore (large sizes). To detach the ball from the spline driver (4), turn the ball to the closed position before lifting. Make sure that the ball is not damaged and put it onto a soft surface (see Figure 18).

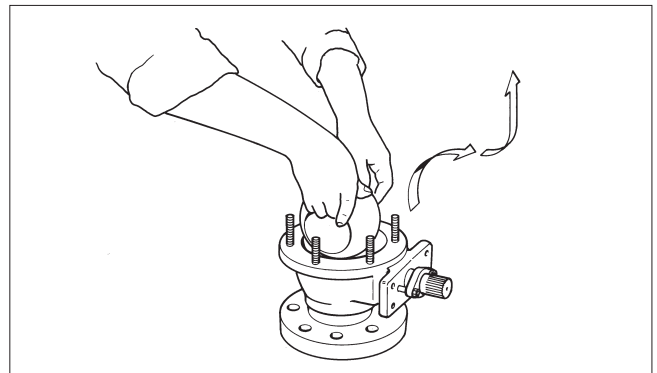

Fig. 18 Removing the ball from the body

- Remove the gland nuts (18), spring sets (150) in live loaded versions, one stud (14), retaining plates (42) and gland (9). Remove the packing (69). Remove the pin (50). Remove the spline driver (2"-8") or thrust ring (1"-1.5") inside the body. For detailed figures to remove the thrust ring see Fig. 19. Remove the shaft (5) by pulling it outwards. Please note that this will detach the thrust bearings (70) from around the shaft.

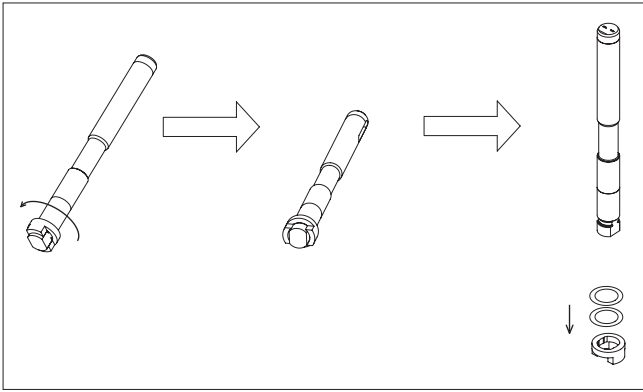

Fig. 19 Detaching the thrust ring in sizes 1" and 1.5"

- For sizes 10"-12", remove the retaining ring (51) before detaching the stem. Use a pointed metal tool and move the stem back and forth sideways. Remove the stem through the body.

Remove the ball seat (7) from the body (1), if necessary with a special tool. Also remove the back seals (63) from the ball seats and the body gasket (65).

Sizes DN 250-600 / 10"-24", trunnion mounted ball

- Place the valve in a standing position on the pipe flange end. Use a level surface that will not scratch the flanges. See that the body stud nuts (16) are facing upward.
- Mark the the body halves for correct orientation during re-assembly.
- Turn the ball to the closed position.
- Remove the key (10).
- Unscrew the gland nuts (18). Remove the disc spring sets (150) and the gland (9).
- Unscrew the body stud nuts (16).
- Remove the body cap (2). If the seat (7) is not lying on the ball (3), prevent the seat from falling from the body cap and detach it later. Don't leave your fingers between the body cap and the surface!
- Place the removed body cap on its pipe flange.
- Remove the seat (7) from body cap (2) if it is still in place.
- Unscrew the bonnet stud nuts (17). Remove the shaft (5) and bonnet (8). Knock the bonnet off with a piece of wood and a hammer, if needed.
- Lift the ball (3) along with the trunnion plates (89) out of the body (1) Handle the ball carefully and place it on a soft surface.
- Remove the seat (7) from the body (1).
- Remove the trunnion plates (89) from the hubs of the ball.
- Remove the trunnion bearings (99) and the bearing spacers (91) from each trunnion.
- Push the shaft out of the bonnet.
- Remove thrust bearings (70, 71) from the shaft and packing rings (69) from the bonnet (8).
- Remove the body gasket (65) and the bonnet gasket (66).

5.7 Checking the parts of a dismantled valve

- Clean the removed parts.
- Check the stem (5) and the thrust bearings (70).
- Check the ball (3) and the ball seats (7).
- Check the body gasket surfaces.
- Replace any damaged parts.

5.8 Replacing parts

Replace soft parts whenever you dismantle the valve for maintenance. Replace other parts when necessary. By using original spare parts, you can ensure proper functioning of the valve. For ordering the spare parts, see Section 9 ('Ordering spare parts').

5.9 Reassembling the valve

Sizes DN 25-300/1"-12", seat supported

CAUTION:

For safety reasons the retaining plates (42) MUST always be installed as shown in 10.1.

- Place the valve body on its pipe flange. Use a surface that does not damage the pipe flange sealing surfaces.
- **P- and S-seats:** Place the back seal (63) in the ball seat (7); see Figures 20 and 21. Place the seat in the body (1).

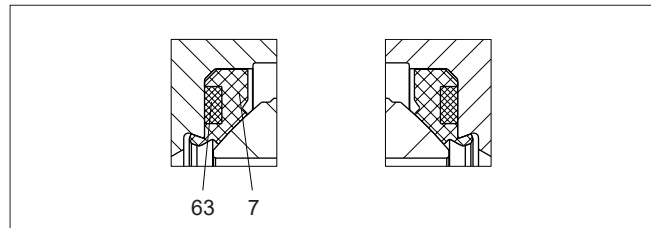

Fig. 20 P-seat

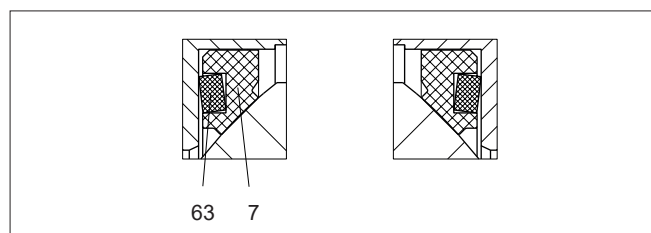

Fig. 21 S-seat

- Lock the P- (7) with a special tool supplied with separate instructions (see Section 8 'Tools').
- **X-, T- and M-seats:** Place the seat (7) in the body (1) and body cap (2).

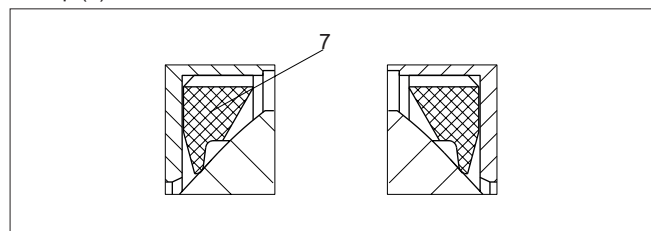

Fig. 22 X-, T- and M-seats

- **E-seat:** Place the back seal (113) in the groove of the seat outer circle (25), Fig. 24. Place the spring (62) in the body. Place the seat in position with a special tool which is supplied with instructions, see Figure 24 and Section 8 'Tools'.

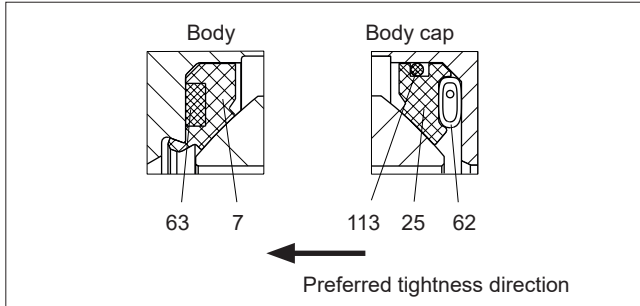

Fig. 23 E-seat

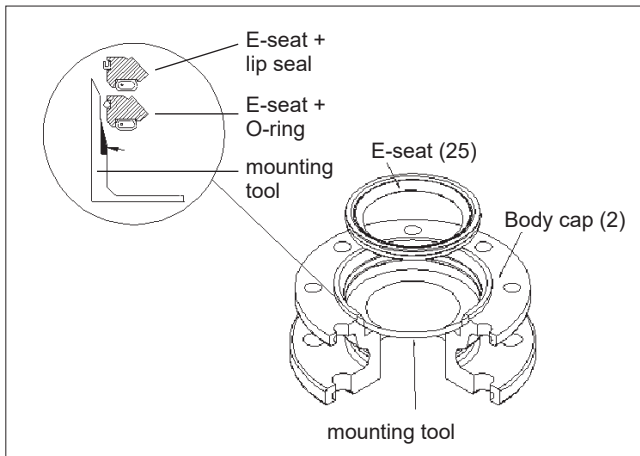

Fig. 24 Mounting the E-seat

- Place the locking wire (51) in the stem groove (5) in sizes DN 50/2"-DN 200/8". Place the stem partly inside the body from above and place the thrust bearings (70) on the stem from inside the body. Place the thrust bearings against the stem shoulder and place the stem in the valve from inside. Place the spline driver (4, sizes DN 50/2"-DN 200/8") on the shaft spline and lock it with a pin (50). Place the thrust ring (4, sizes DN 25/1"-DN 40/1.5") on the shaft and lock it as illustrated in Fig. 25. Put the ball (3) in its position so that the spline driver / thrust ring (4) is in the ball slot. Screw down the studs (14). Place the support ring (67, sizes DN 50/2"-DN 200/8"), the packing (69), the gland (9) and the retaining plates (42) in their position. Place the nuts (18) on the studs (14) and screw down them gently.

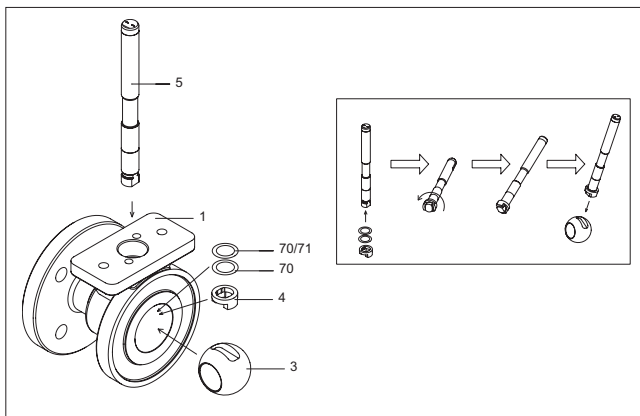

Fig. 25 Assembling the shaft in sizes 1" and 1.5"

- Place the body gasket (65) in the body groove. Screw the studs (12) into the body (1). In sizes DN 25/1" and DN 40/1.5" there are through holes both in body and cap and the joint is made with nuts in both ends of the studs
- Carefully place the body cap (2) on the body. Make sure that the marks made during dismantling are aligned.
- Tighten the body nuts (16). For the best results, press the valve parts against each other. If this is not possible, make sure that you tighten the nuts evenly. The torque is shown in Table 3, section 4.9.4.
- To make sure that the ball lies properly between the seats, turn the stem slowly in both directions two or three times.
- Tighten the nuts (18) of the gland by hand as tightly as possible and after that as shown in the instructions in Section 4.2. In case of leakage through the packing of a pressurized valve, carefully tighten the nuts until the leakage stops.
- Observe the same caution in reinstalling the valve that you used in dismantling it. Please also note the instructions in Section 3.

Locking of the seat

A seat locking tool (can be ordered from the manufacturer) and a hydraulic press with suitable capacity are needed for locking.

- Mount the seat with the back seal as described in the earlier section.
- Mount the locking tool carefully over the seat, see Fig. 26.
- Place the valve body/body cap on the bed of the press. The bed surface must be level and non-scratching.
- Align the valve and locking tool properly with the piston of the press.
- Press the tool to lock the seat. See Table 2 for pressing forces.
- Remove the body/body cap from the press and continue the reassembly as described in the earlier section.

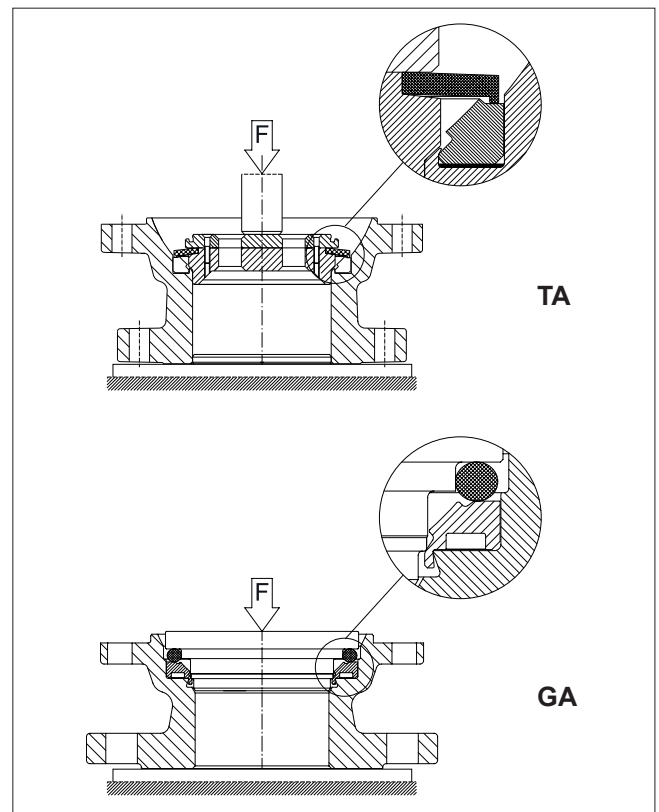

Fig. 26 Locking of the seat

Table 2 Pressing forces for seat locking

Valve size	Force (kN)
TA construction	
02	70
03	140
04	160
06	250
08	370
GA construction	
01	55
1H	75
02	130
03	110
04	125
06	200
08	400

Sizes DN 250-600 / 10"-24", trunnion mounted ball

- Place the valve body (1) and the body cap (2) on the pipe flange end. Use a level surface that will not scratch the flange sealing surfaces.

S-, T-, and P seats: Check the sealing surfaces

- Place the back seal (O-ring) (63) into the groove in the seat. See Figures 27, 28 and 29..
- Place the back-up rings (64) made of PTFE strips at the side of the O-ring. To ensure that the seam becomes flexible, the strip must have slanted ends.
- For easier assembly, lubricate the O-ring and back-up ring surfaces facing the seats with silicone grease or another suitable substance. Please ensure the compatibility with the flow medium.

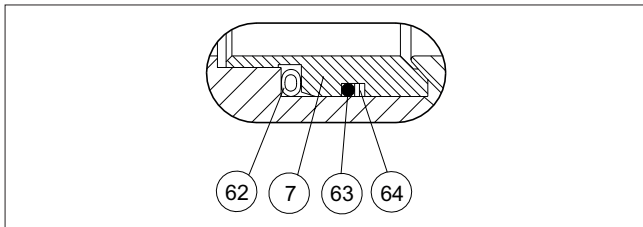

Fig. 27 S-seat

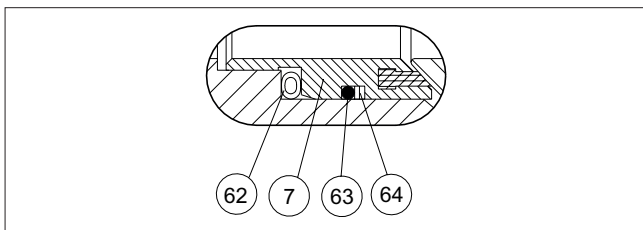

Fig. 28 T-seat

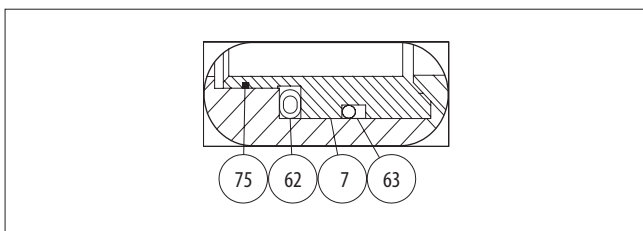

Fig. 29 P-seat

- Place the spring (62) into the groove in the seat (7). Connect the ends of the spring.
- Place the seats into the body and body cap by hand or if necessary, using a plastic mallet. The seat is in correct position when the spring touches the body shoulder.
- Place a trunnion bearing (99) into each trunnion plate (89) counterbore.
- Place a bearing spacer (91) over each ball trunnion.
- Fit a trunnion plate over each ball trunnion until the plate rests against the bearing spacer (91). This operation must be performed with care and without excessive force or the bearing will be damaged. It may be necessary to tap the plate on with a plastic mallet.
- Align the trunnion plates (89) relative to the ball port in the closed position.

NOTE:

The shaft will fit into the ball in one position only. There's a larger cog in the splined shaft or added cog in square end shaft and a matching groove in the ball shaft bore. It is essential to note the groove's position during the next assembly step.

- With the ball (3) in the "closed" position, lower the ball/trunnion plate subassembly into the body (1).
NOTE: This procedure is critical and careful attention is a must. The outside diameter of the trunnion plates must pilot in the body counterbore. Carefully lower the subassembly until a trunnion plate enters the counterbore (Usually one trunnion plate will enter the counterbore and the other will be out of position.) Use a plastic mallet or a block of wood to rotate the second trunnion into position. Once trunnion plates are aligned, lower the subassembly until the trunnion plates are seated in the bottom of the counterbore.
- Insert shaft subassembly through the bonnet (8) and install packing (69). Refer to Fig. 15 for proper orientation of packing.
- Install the gland (9) over shaft (5) and gland studs. Install the disc springs sets (150) and the gland stud nuts (18) on studs and tighten "finger tight."
- Install the bonnet gasket (66) and the bonnet subassembly over the bonnet studs (10). Note the correct shaft position! Lubricate the threads of studs (13) and tighten the nuts (17) according to values in Table 2.
- Install the body gasket (65) in the body groove.
- Place the body cap (2) carefully over the body studs (12) and the body (1). See that the flange holes are aligned acc. to the mark made during the dismatling. Take care not to damage the body gasket and the seat (7) in the body cap.
- Fasten the body nuts (16). Tighten the nuts gradually, always switching to other side of the valve after every nut. The recommended torques are given in Table 2. The flange faces must in even contact with each other.
- Mount the key (10).
- Cycle the valve slowly a couple of times to insure correct position of the ball between the two seats.
- Pull on the shaft (5) while tightening to assure that shaft and thrust bearings are always in contact with the body. Tighten the gland nuts (18) acc. to Section 4.2 . Check for leakage once the valve is pressurized.
- Install the valve in the pipeline as carefully and accurately as when removing it. Follow the instructions given in Section 3.

Tightening torques of the body joint bolting

Table 3 Tightening torques of the body stud nuts

Material	ISO 3506 A2-70	ASTM A193 gr. B8M cl. 1	ASTM A193 gr. B8M cl. 2
Bolt Size	Tightening Torque (Nm)	Tightening Torque (Nm)	Tightening Torque (Nm)
M8	21	11	31
M10	41	22	60
M12	70	38	100
M14	110	61	170
M16	170	95	260
M18	240	130	350
M20	340	190	420
M22	460	250	560
M24	590	320	720
M27	870	480	870
M30	1200	650	1200
M33	1600	880	1200
M36	2100	1100	1600
M39	2700	1500	2100

NOTE: Threads must be well lubricated

NOTE: ISO 3506 A2-70 utilized in M1 series. ASTM A193 B8M cl.1 utilized in M2 sizes 1"-16", ASTM A193 cl.2 utilized in M2 sizes 18"-24"

6. TESTING THE VALVE

CAUTION:

For pressure testing, use equipment conforming to the correct pressure class!

Test the valve's body pressure after reassembly.

Test the pressure in accordance with an applicable standard. Use the pressure required by the pressure class or the flange bore. Keep the valve in the half open position during the test.

If the tightness of the closure member is also to be tested, please contact the manufacturer.

7. INSTALLING AND DETACHING THE ACTUATORS

7.1 General

CAUTION:

Beware of ball movement!

CAUTION:

Do not detach a spring-return actuator unless a stop-screw is carrying the spring force!

Use suitable mounting parts and couplings when you install the actuators.

7.2 Installing the M actuator

- The mark at the end of the stem indicates the direction of the ball flow bore. Turn the valve to the closed position.
- Lubricate the grooves of the actuator and the couplings. Place the coupling on the stem and lock it. Place the bracket on the valve and turn the lubricated screws a few times.
- Turn the actuator to the closed position and push it carefully onto the valve stem on which the coupling has been mounted. Please note the marks on the handwheel and the coupling.
- Lubricate the actuator screws. Tighten all screws.
- Adjust the circular movement of the ball with the hexagon screws located at the side of the housing (see Figure 29). The stop-screw for the open position is nearest to the handwheel on the side of the housing and the screw for the closed position is at the opposite end. The turning directions for the handwheel are marked on the wheel.
- Check the handwheel by turning the valve to the extreme positions. The yellow arrow should indicate the direction of the ball flow bore.

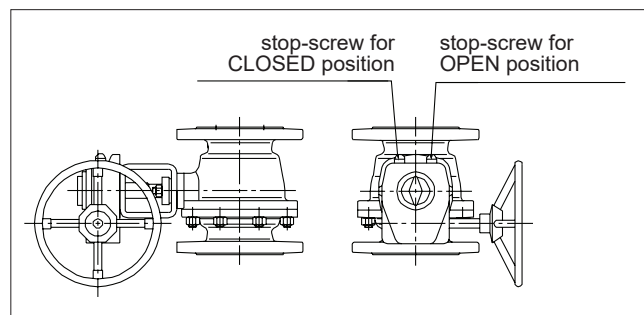

Fig. 30 Open and closed positions of the M actuators

7.3 Installing the B1C actuator

- Turn the valve to the closed position and drive actuator piston to the extreme outward position.
- File off any burrs and clean the stem bore.
- Place the coupling (not always needed) over the stem.
- Note the correct position. The line at the end of the stem (and coupling) indicates the direction of the ball flow bore.
- Lubricate the (coupling and) stem bore. Fasten the bracket loosely to the valve.
- Slip the actuator carefully onto the coupling/stem. We recommend mounting the actuator so that the cylinder is pointing upwards.
- Position the actuator parallel or vertical to the pipeline as accurately as possible. Lubricate the actuator mounting screws and then fasten all screws.
- Adjust the ball open and closed positions by means of the actuator stop screws located at both ends (see Fig. 30). An accurate open position can be seen in the body flow bore. Check that the yellow arrow on the actuator indicates the ball flow opening position. **Watch out for your hand!**

There is no need for stop screw adjustment if the actuator is re-installed in the same valve. Drive actuator piston to the housing end (open position). Turn the actuator by hand until the valve is in the open position. Fasten the actuator in this position as explained above.

- Check the stop screw thread tightness. An O-ring is used for sealing.

- Check that the actuator is functioning correctly. Drive the actuator piston to both cylinder ends and check the ball position and its movement with respect to the actuator (close: clockwise; open: counterclockwise). The valve should be closed when the piston is in the extreme outward position.
- If necessary, change the position of the actuator pointing cover to correctly indicate the valve open/closed position.

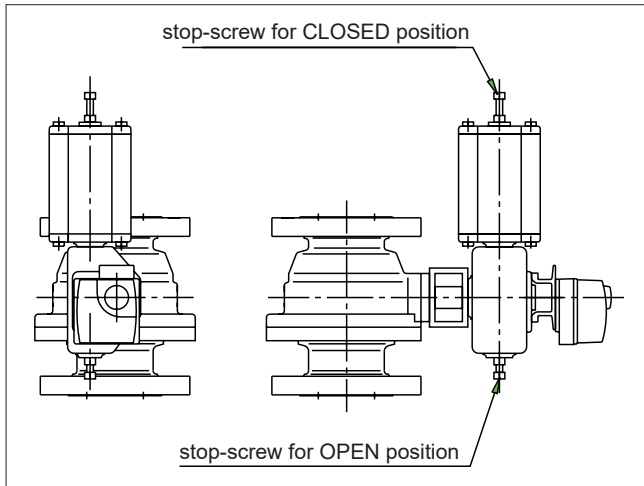

Fig. 31 Open and closed positions of the B series actuators

7.4 Installing the B1J actuator

Spring-return actuators are used in applications where valve opening or closing movement is needed in case the air supply is interrupted. The B1J type is used for spring-to-close operation; the spring pushes the piston towards the cylinder end, the extreme outward position. In turn, the B1JA type is used for spring-to-open operation; the spring pushes the piston towards the housing.

Spring-return actuators are installed in a manner similar to B1C-series actuators, taking into account the following.

B1J type

- Install the actuator so that the piston is in the extreme outward position. The cylinder must not be pressurized and air supply connections must be open. The valve must be in the **closed** position.

B1JA type

- Install the actuator so that the piston is in the cylinder end position at housing side. The cylinder must not be pressurized and air supply connections must be open. The valve must be in the **open** position.
- The rest of the installation procedure is the same as in section 6.3.

7.5 Detaching B series actuators

- Disconnect the actuator from its power source; detach the air supply pipe and control signal cables or pipes from their connectors.
- Unscrew the bracket screws.
- Detach the actuator using a suitable extractor, see Fig. 31. The tool can be ordered from the manufacturer.

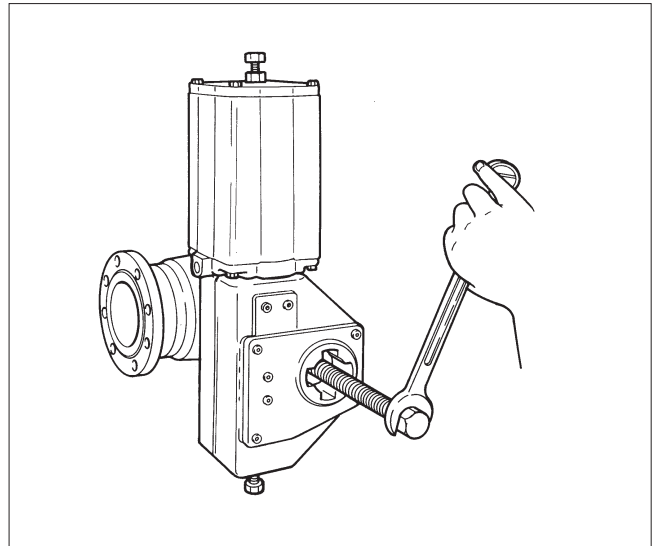

Fig. 32 Extractor

7.6 Installing other manufacturer's actuators

NOTE:

Valmet accepts no responsibility for compatibility of actuators not installed by Valmet.

Other actuators can be installed only if they have an ISO 5211 actuator connection.

8. TROUBLE SHOOTING TABLE

The following Table 4 lists malfunctions that might occur after prolonged use.

Table 4 Trouble shooting

Symptom	Possible fault	Recommended action
Leakage through a closed valve	Wrong stop screw adjustment of the actuator	Adjust the stop screw for closed position
	Faulty zero setting of the positioner	Adjust the positioner
	Damaged seat	Replace seat
	Damaged closing member	Replace the closing member
	Closing member in a wrong position relative to the actuator	Select the correct keyway in the actuator
Leakage through body joint	Damaged gasket	Replace the gasket
	Loose body joint	Tighten the nuts or screws
Irregular valve movements	Actuator or positioner malfunction	Check the operation of the actuator and positioner
	Process medium accumulated on the sealing surface	Clean the sealing surfaces
	Closing member or seat damaged	Replace the closing member or seat
	Crystallizing medium has entered the bearing spaces	Flush the bearing spaces
Gland packing leaking	Gland packing worn or damaged	Replace the gland packing
	Loose packing	Tighten the packing nuts

9. TOOLS

In addition to standard tools, the following special tools might be needed.

- For removal of the actuator:
Extractor tools (Actuator Series B1C/B1J)

Product:	ID:
B1C/B1J 6	303821
B1C 8-11 / B1J 8-10	8546-1
B1C 12-17 / B1J 12-16	8546-2
B1C/B1J 20	8546-3
B1C/B1J 25	8546-4
B1C/B1J 32	8546-5
B1C 40 / B1J 322	8546-6
B1C 50	8546-7
B1C 502	8546-8

- For removal of the locked seats:
Seat removal tool for P-seat.

Product size:	ID:
DN 25 (1")	270073
DN 40 (1½")	270075
DN 50 (2")	270076
DN 65 (2½")	278746
DN 80 (3")	270078
DN 100 (4")	270079
DN 125	270081
DN 150 (6")	270083
DN 200 (8")	270085
DN 250 (10")	270086
DN 300 (12")	270087
DN 350 (14")	280996
DN 400 (16")	280997

- For locking of the seats:
Seat locking tools / Insertion tools (M series P seats & X series GA type K seats)

Product:	ID:
M1MA025P (1")	H018890
M1MA040P (1½")	H018889
M1MA050P (2")	H018886
M1MA065P (2½")	H021153
M1MA080P (3")	H018885
M1MA100P (4")	H018881
M1MA125P (5")	H027818
M1MA150P (6")	H016886
M1MA200P (8")	H018555
M1MA250P (10")	H018556
M1MA300P (12")	H018557

- For mounting the E-seat
- mounting tool

These tools can be ordered from the manufacturer. Always give the valve type designation when ordering.

If you require additional assistance, please contact the manufacturer or manufacturer's representative.

10. ORDERING SPARE PARTS

When ordering spare parts, always include the following information:

- type code, sales order number, serial number (stamped on a valve body)
- number of the parts list, part number, name of the part and quantity required

This information can be found from the identification plate or documents.

11. EXPLODED VIEWS AND PARTS LISTS

11.1 Sizes DN 25-40 / 1"-1.5", seat supported ball

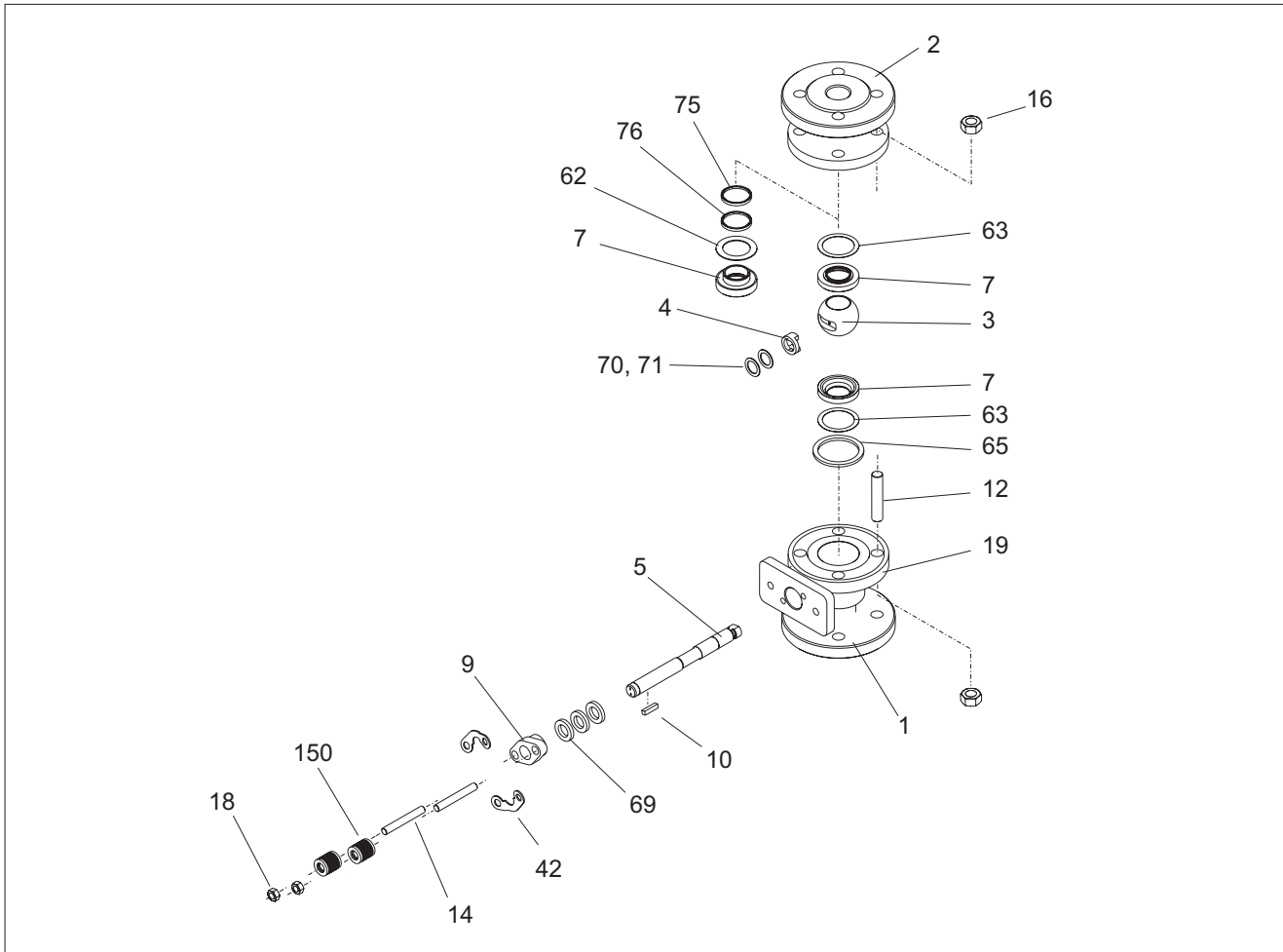

Item	Qty	Description	Spare part category
1	1	Body	
2	1	Body cap	
3	1	Ball/Q-TRIM ball	3
4	1	Spline driver (2" - 8" / DN 50 - 200) Thrust ring (1", 1 1/2" / DN 25, 40)	3
5	1	Shaft	3
7	1, 2	Ball seat	2
9	1	Gland	
10	1	Key	3
12	4	Stud	
14	2	Stud	
16	8	Hexagon nut	
18	2	Hexagon nut	
19	1	ID plate	
25	1	Ball seat (H)	
42	2	Retaining plate	
50	1	Locking pin	
62	1	Seat spring	1
63	2	Back seal	1
65	1	Body gasket	1
69	1	Packing ring (set)	1
70	1	Thrust bearing	1
71	1	Thrust bearing	
75	1	Seat seal (H)	
76	1	Back-up ring	
150	2	Disc ring set	

Spare part category 1: Recommended soft parts, always needed for the repair. Delivered as a set.

Spare part category 2: Parts for replacing of the seat. Delivered as a set.

Spare part category 3: Parts for replacing of the closing element.

Spares for the full overhaul: All parts from the categories 1, 2 and 3.

11.2 Sizes DN 50-200 / 2"-8", seat supported ball

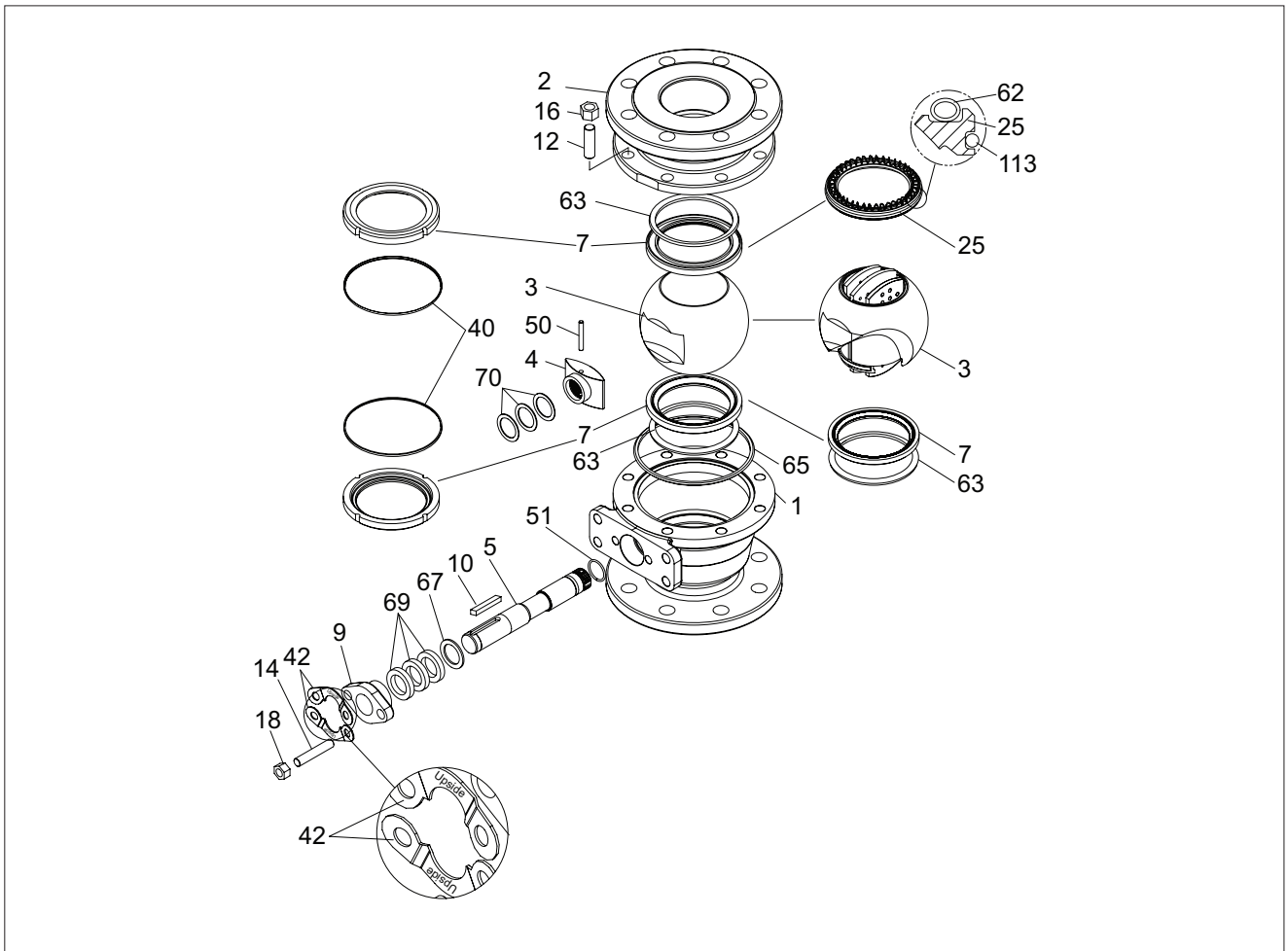

Item	Qty.	Description	Spare part category
1	1	Body	
2	1	Body cap	
3	1	Ball 1 Q-ball	3
4	1	Spline driver	3
5	1	Stem	3
7	2	Seat (P/S/K, T or M)	2
7	1	Seat (K), when E seat in the body cap	
9	1	Gland	
10	1	Key	3
12		Stud	
14	2	Stud	
16		Hexagon nut	
18	2	Hexagon nut	
25	1	Seat (E), when K seat in the body	
40	2	Lock ring (T/M)	
42	2	Retaining plate	
50	1	Cylindrical pin	
51	1	Retaining ring	
62	1	Spring (E)	1
63	2	Back seal (P/S/K)	1
	1	Back seal (S/K), when E seat in the body cap	1
65	1	Body gasket	1
67	1	Thrust ring	
69	1	Packing (set)	1
70	3	Thrust bearing	1
113	1	O-ring (E) / lip seal (E)	

Spare part category 1: Recommended soft parts, always needed for the repair. Delivered as a set.

Spare part category 2: Parts for replacing of the seat. Delivered as a set.

Spare part category 3: Parts for replacing of the closing element.

Spares for the full overhaul: All parts from the categories 1, 2 and 3.

11.3 Sizes DN 250-300 / 10"-12", seat supported ball

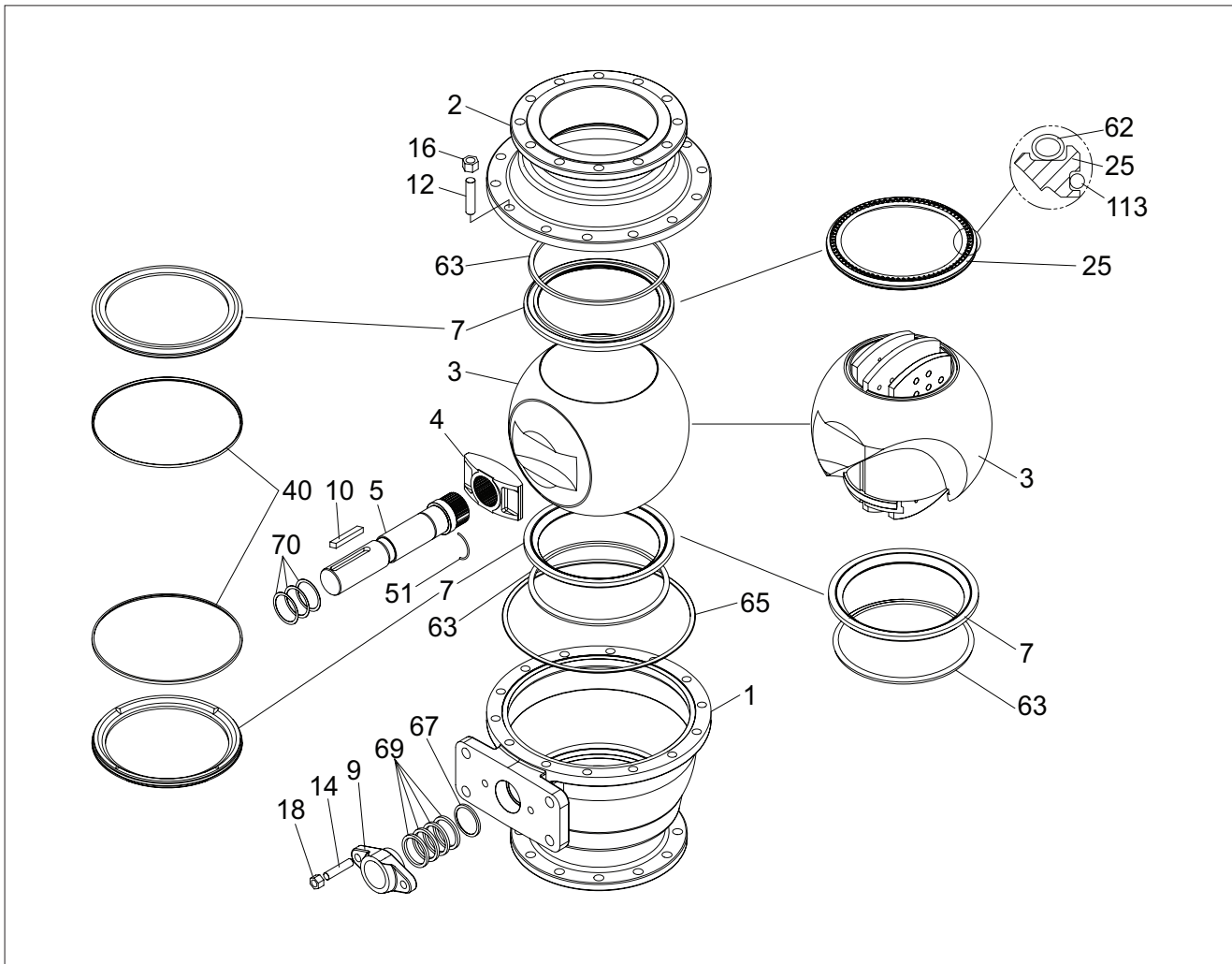

Item	Qty.	Description	Spare part category
1	1	Body	
2	1	Body cap	
3	1	Ball	3
3	1	Q-ball	3
4	1	Spline driver	3
5	1	Stem	3
7	2	Seat (P/S/K, T or M)	2
7	1	Seat (K), when E-seat in the body cap	2
9	1	Gland	
10	1	Key	3
12		Stud	
14	2	Stud	
16		Hexagon nut	
18	2	Hexagon nut	
25	1	Seat (E), when K-seat in the body	
40	2	Lock ring (T/M)	
51	1	Retaining ring	
62	1	Spring (E)	1
63	2	Back seal (P/S/K) 1 Back seal (S/K), when E-seat in the body cap	1
65	1	Body gasket	1
67	1	Thrust ring	
69	1	Packing (set)	1
70	3	Thrust bearing	1
113	1	O-ring (E) / lip seal (E)	

Spare part category 1: Recommended soft parts, always needed for the repair. Delivered as a set.

Spare part category 2: Parts for replacing of the seat. Delivered as a set.

Spare part category 3: Parts for replacing of the closing element.

Spares for the full overhaul: All parts from the categories 1, 2 and 3.

11.4 Sizes DN 250-400 / 10"-16", trunnion mounted ball

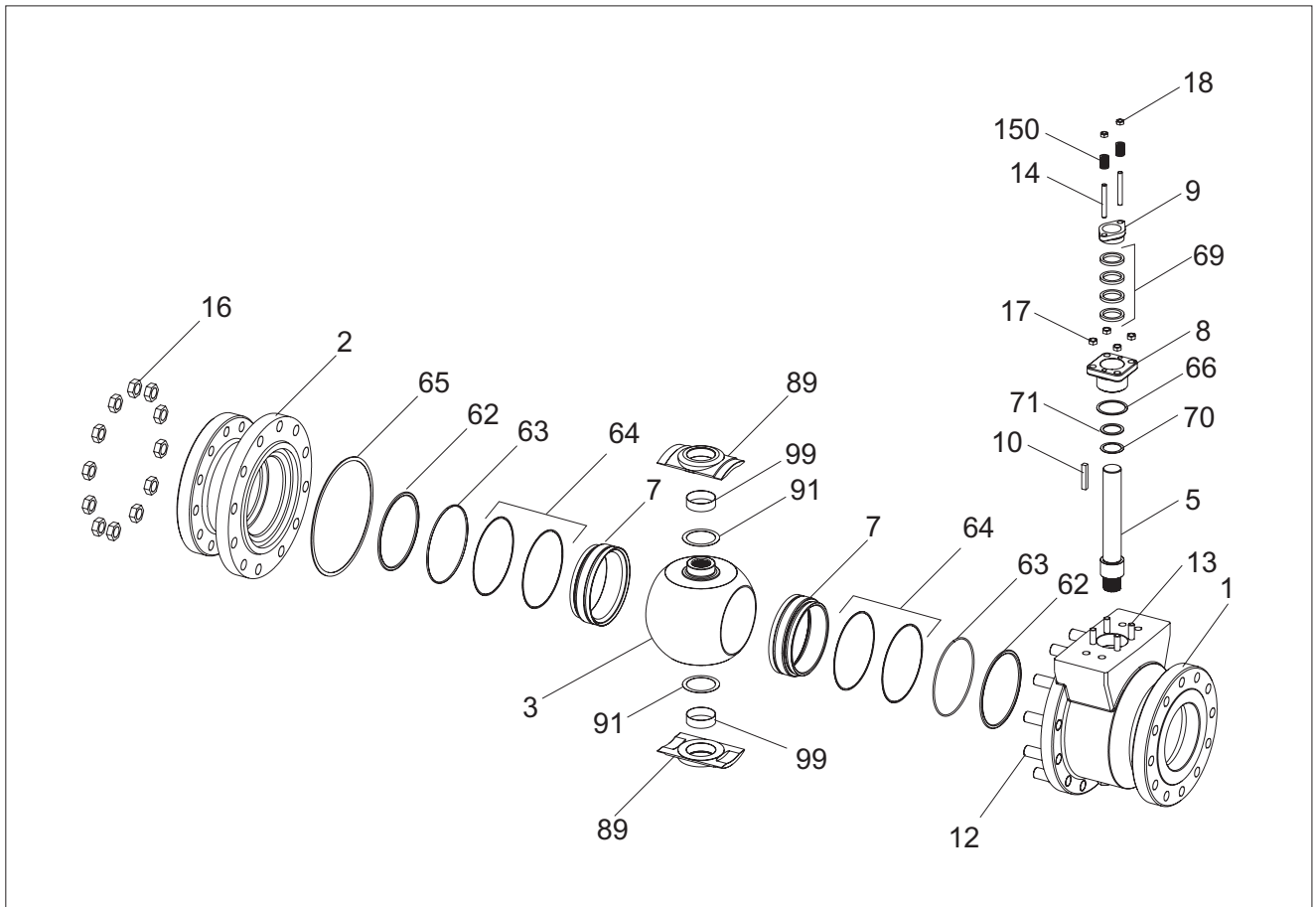

Item	Qty.	Description	Spare part category
1	1	Body	
2	1	Body cap	
3	1	Ball	3
5	1	Shaft	3
7	1 or 2	Seat (S, T)	2
	1 or 2	Seat (H)	
8	1	Bonnet	
9	1	Gland	
10	1	Key	3
12		Stud	
13		Stud	
14		Stud	
16		Hexagon nut	
17		Hexagon nut	
18		Hexagon nut	
62	1	Spring	
63	2	O-ring (S, T)	1
	1	Back seal (H)	1
64	2	Back-up ring	
65	1	Body gasket	1
66	1	Bonnet gasket	1
69	1	Packing / V-ring set	1
70	2	Thrust bearing (S, T)	3
	1	Thrust bearing (H)	3
71	1	Thrust bearing	
89	2	Trunnion plate	
91	2	Bearing spacer	3
99	2	Trunnion bearing	3
150	2	Disc spring set	

Spare part category 1: Recommended soft parts, always needed for the repair. Delivered as a set.

Spare part category 2: Parts for replacing of the seat. Delivered as a set.

Spare part category 3: Parts for replacing of the closing element.

Spares for the full overhaul: All parts from the categories 1, 2 and 3.

11.5 Sizes DN 450-600 / 18"-24", trunnion mounted ball

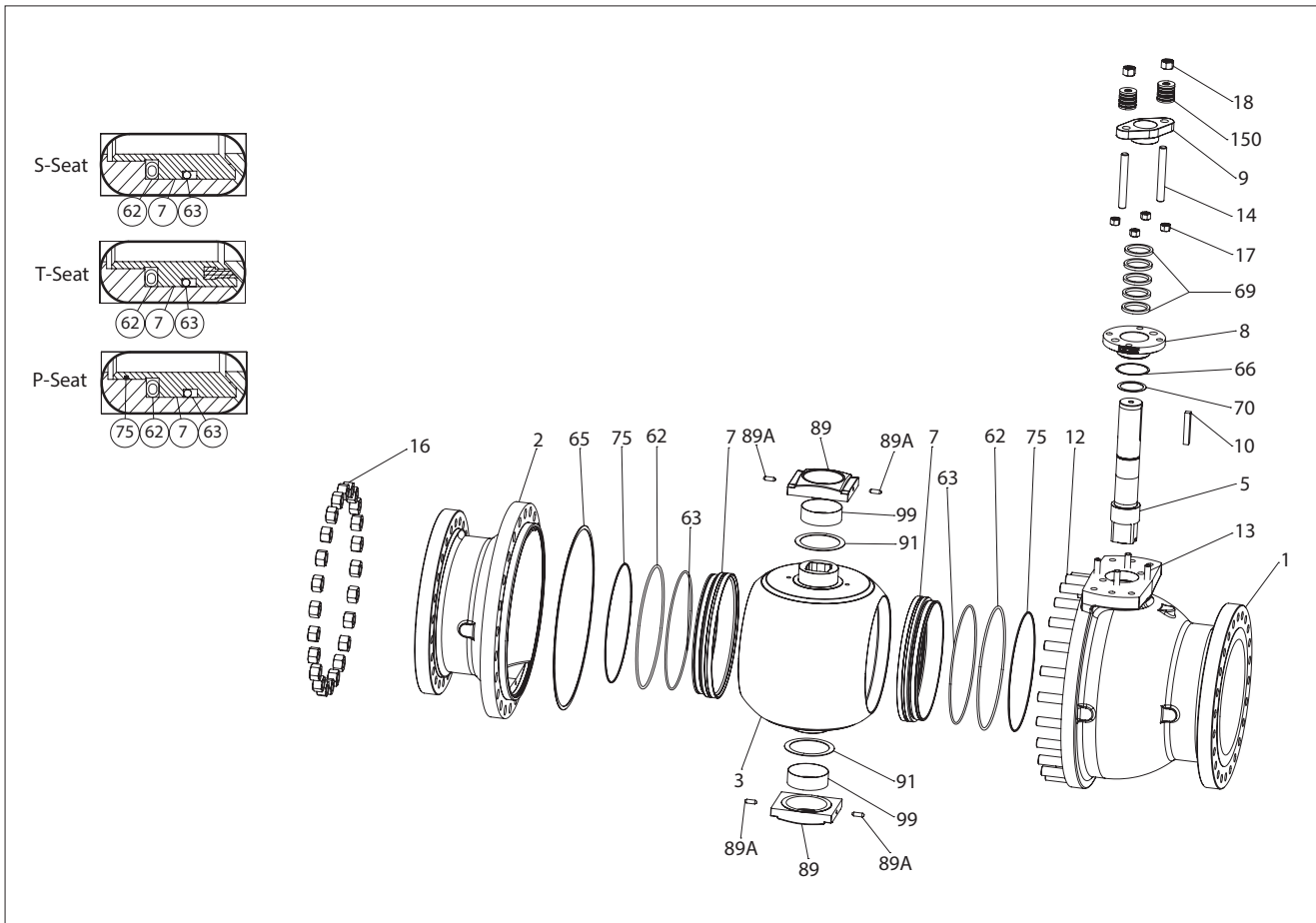

Item	Qty	Description	Spare part category
1	1	BODY	
2	1	BODY CAP	
3	1	BALL	3
5	1	SHAFT	3
7	1 or 2	SEAT (S, P, T)	2
8	1	BONNET	
9	1	GLAND	
10	1	KEY	3
12		STUD	
13		STUD	
14		STUD	
16		HEXAGON NUT	
17		HEXAGON NUT	
18		HEXAGON NUT	
19	1	IDENTIFICATION PLATE	
36	1	ANTI-STATIC SPRING	3
62	1 or 2	SPRING	2
63	1 or 2	O-RING	1
65	1	BODY SEAL SPIRAL WOUND	1
66	1	SHEET RING	1
69	1	V-RING SET	1
70	1	THRUST BEARING	1
75	1 or 2	BRAIDED SEAL SQUARE (P)	1
89	2	TRUNNION PLATE	
89A	4	PIN	1
91	2	THRUST BEARING	1
99	2	TRUNNION BEARING	1
150	2	DISC SPRING SET	

Spare part category 1: Recommended soft parts, always needed for the repair. Delivered as a set.

Spare part category 2: Parts for replacing of the seat. Delivered as a set.

Spare part category 3: Parts for replacing of the closing element.

Spares for the full overhaul: All parts from the categories 1, 2 and 3.

12. DIMENSIONS AND WEIGHTS

12.1 Seat supported valves

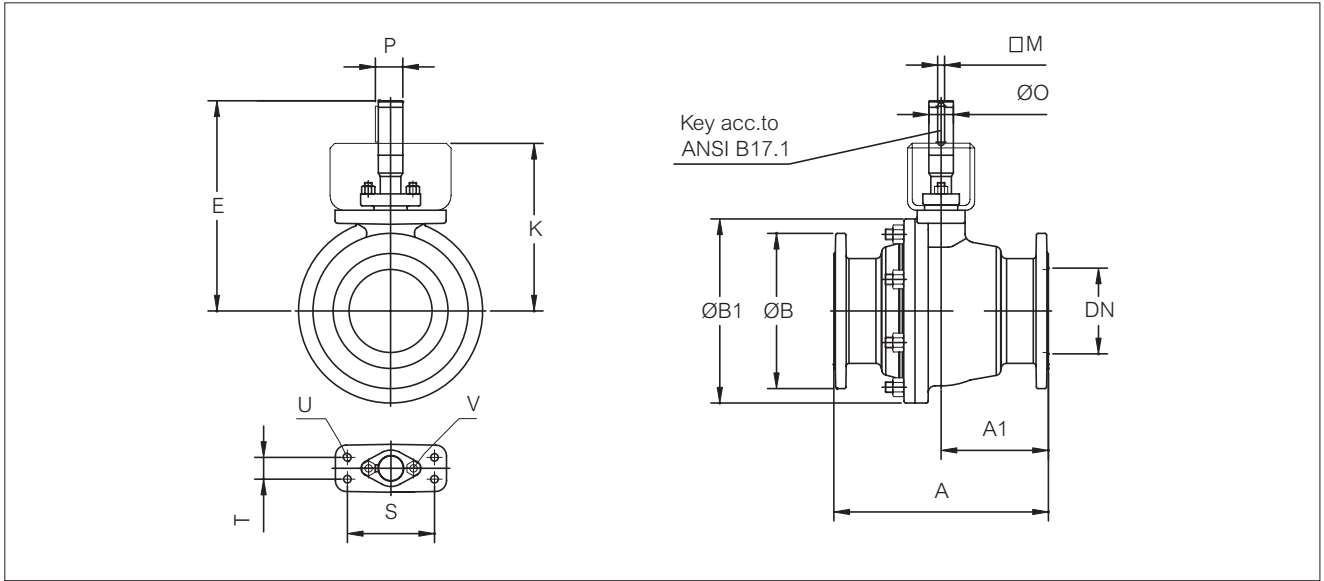

TYPE PN	DN	DIMENSIONS (mm)												WEIGHT (kg)		
		A	A1	ØB	ØB1	E	K	M	ØO	P	S	T	U	V	M1	Q-M1
M1M PN40 (10, 16, 25)	25	165	74	124	110	178	150	4.76	15	17	70	-	M10	M8	5	-
	40	165	70	155	145	206	168	4.76	20	22	70	-	M10	M10	8	-
	50	178	79	165	146	215	168	6.35	25	27.8	110	32	M12	M10	13	14
M1M PN40 (25)	65	270	135	185	154	223	176	6.35	25	27.8	110	32	M12	M10	20	-
	80	282	141	200	195	237	190	6.35	25	27.8	110	32	M12	M10	30	32
	100	305	152.5	235	252	309	250	9.52	35	39.1	130	32	M12	M10	50	55
	125	325	162.5	270	280	331	272	9.52	35	39.1	130	32	M12	M10	80	-
	150	403	201.5	300	346	386	305	12.70	45	50.4	160	40	M16	M14	120	130
M1L PN25	200	502	251	360	432	476	385	12.70	55	60.6	160	55	M20	M14	200	220
	250	568	284	425	512	582	472	15.87	65	71.9	230	90	M24	M20	295	335
	300	648	324	485	584	685	555	19.05	75	83.1	307.4	120	M30	M20	450	505
M1K PN16 (10)	65	270	135	185	154	223	176	6.35	25	27.8	110	32	M12	M10	20	-
	80	203	101.5	200	184	237	190	6.35	25	27.8	110	32	M12	M10	20	22
	100	229	114.5	220	236	309	250	9.52	35	39.1	130	32	M12	M10	35	37
	125	325	162.5	270	280	331	272	9.52	35	39.1	130	32	M12	M10	80	-
M1K PN16	150	394	197	285	338	386	305	12.70	45	50.4	160	40	M16	M14	100	110
	200	457	228.5	340	426	476	385	12.70	55	60.6	160	55	M20	M14	160	180
	250	533	266.5	405	512	582	472	15.87	65	71.9	230	90	M24	M20	280	320
M1J PN10	300	610	305	460	584	685	555	19.05	75	83.1	307.4	120	M30	M20	420	475
	200	457	228.5	340	426	476	385	12.70	55	60.6	160	55	M20	M14	160	180
	250	533	266.5	405	512	582	472	15.87	65	71.9	230	90	M24	M20	280	320
	300	610	305	460	584	685	555	19.05	75	83.1	307.4	120	M30	M20	420	475

TYPE Class	NPS	DIMENSIONS (mm)												WEIGHT (kg)		
		A	A1	ØB	ØB1	E	K	M	O	P	S	T	U	V	M2	Q-M2
M2C Class 150	1	165*	74	124	110	178	150	4.76	Ø 15	17	70	-	M10	M8	5	-
	1 1/2	165	70	155	145	206	168	4.76	Ø 20	22	70	-	M10	M8	8	-
	2	178	79.0	152.4	146	215	168	6.35	Ø 25	27.8	110	32	M12	3/8	11	12
	3	203	101.5	190.5	190	237	190	6.35	Ø 25	27.8	110	32	M12	3/8	25	27
	4	229	110.5	228.6	241	309	250	9.52	Ø 35	39.1	130	32	M12	3/8	40	43
	6	394	197.0	279.5	342	386	305	12.70	Ø 45	50.4	160	40	M16	1/2	100	110
	8	457	228.5	342.9	430	476	385	12.70	Ø 55	60.6	160	55	M20	1/2	175	195
	10	533	266.5	406.4	512	582	472	15.87	Ø 65	71.9	230	90	M24	3/4	290	330
M2D Class 300	12	610	305.0	482.6	592	685	555	19.05	Ø 75	83.1	307	120	M30	3/4	460	515
	1	165	74.0	124.0	110	178	150	4.76	Ø 15	17.0	70	-	M10	M8	5	-
	1 1/2	191	70.0	155.0	145	206	168	4.76	Ø 20	22.0	70	-	M10	M8	10	-
	2	216	89.0	165.1	146	215	168	6.35	Ø 25	27.8	110	32	M12	3/8	15	17
	3	282	141.0	209.6	200	237	190	6.35	Ø 25	27.8	110	32	M12	3/8	35	37
	4	305	152.5	254.0	254	309	250	9.52	Ø 35	39.1	130	32	M12	3/8	60	63
	6	403	201.5	317.5	353	386	305	12.70	Ø 45	50.4	160	40	M16	1/2	135	145
	8	419	209.5	381.0	462	476	385	12.70	Ø 55	60.6	160	55	M20	1/2	240	260
10**	457	208.0	445.5	552	582	472	15.87	Ø 65	71.9	230	90	M24	3/4	365	405	
12**	502	223.0	520.7	626	685	555	19.05	Ø 75	83.1	307	120	M30	3/4	545	600	

* Note: class 150 NPS01" face to face length is according to ASME B16.10 Table 2, same as in class 300 NPS01"

** Note: in sizes Class 300 NPS10" and 12" body side flange is with threaded bolt connection (lug style).

12.2 Trunnion type valves

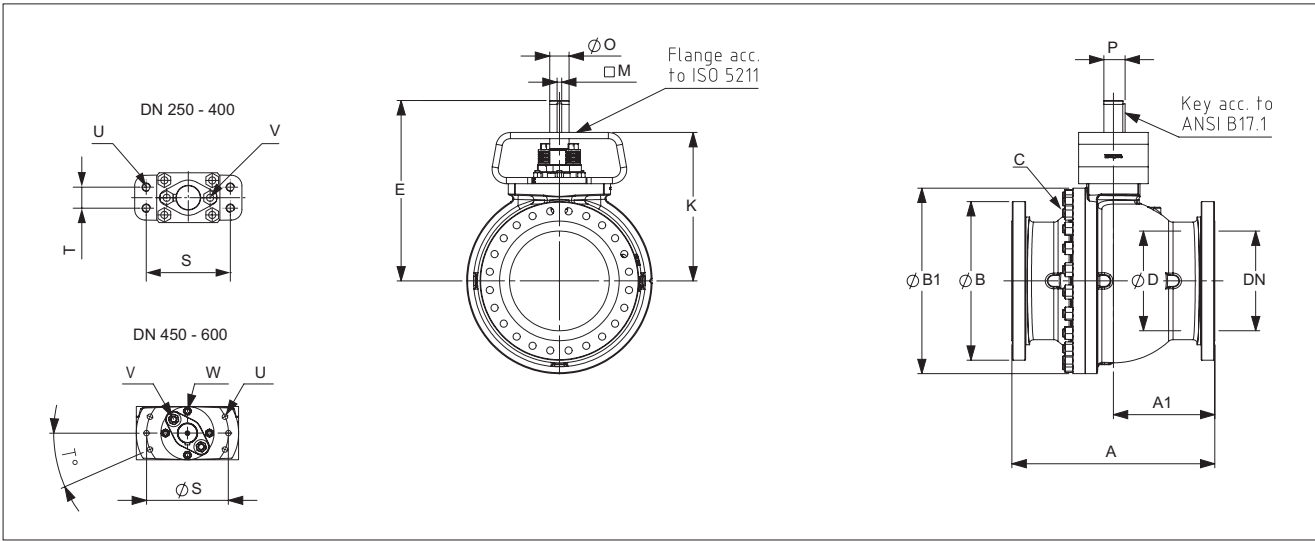

TYPE PN	DN	DIMENSIONS (mm)												WEIGHT (kg)		
		A	A1	ØB	ØB1	E	K	M	ØO	P	S	T	U	V	M1	Q-M1
M1JW/M1JZ PN 10	250	533	267	395	514	562	472	12.70	55	60.60	230	90	M24	M14	325	360
	300	610	305	445	592	605	515	12.70	55	60.60	230	90	M24	M14	480	530
	350	686	343	505	665	741	607	19.05	75	83.15	330	120	M30	M20	635	710
	400	762	381	565	750	779	633	22.23	85	94.63	330	120	M30	M20	840	940
M1KW/M1KZ PN 16	250	533	267	405	514	562	472	12.70	55	60.60	230	90	M24	M14	325	360
	300	610	305	460	592	605	515	12.70	55	60.60	230	90	M24	M14	480	530
	350	686	343	520	665	741	607	19.05	75	83.15	330	120	M30	M20	635	710
	400	762	381	580	750	779	633	22.23	85	94.63	330	120	M30	M20	840	940
M1LW/M1LZ PN 25	250	568	284	425	580	562	472	12.70	55	60.60	230	90	M24	M14	330	370
	300	648	324	485	652	605	515	12.70	55	60.60	230	90	M24	M14	610	660
	350	762	381	555	665	741	607	19.05	75	83.15	330	120	M30	M20	680	750
	400	838	419	620	750	779	633	22.23	85	94.63	330	120	M30	M20	890	980
M1MW/M1MZ PN 40	250	568	284	450	580	562	472	12.70	55	60.60	230	90	M24	M14	330	370
	300	648	324	515	652	605	515	12.70	55	60.60	230	90	M24	M14	610	660
	350	762	381	580	700	741	607	19.05	75	83.15	330	120	M30	M20	800	870
	400	838	419	660	799	779	633	22.23	85	94.63	330	120	M30	M20	1015	1100

TYPE	DN	DIMENSIONS (mm)														WEIGHT		
		ØD	A	A1	ØB	ØB1	E	K	M	ØO	P	ØS	T	U	V	W	C	kg
M1JW/M1JZ PN 10	450	436	864	432	615	800	794	648.5	22.23	85	94.63	330	21.3	M30	M20	M20	M27	981
	500	487	914	457	670	885	811.5	665.5	22.23	85	94.63	330	21.3	M30	M20	M20	M27	1288
	600	589	1067	533.5	780	1041	987	831	22.23	95	104.83	400	23.6	M30	M30	M24	M30	2037
M1KW/M1KZ PN 16	450	436	864	432	640	800	794	648.5	22.23	85	94.63	330	21.3	M30	M20	M20	M27	1011
	500	487	914	457	715	885	811.5	665.5	22.23	85	94.63	330	21.3	M30	M20	M20	M27	1328
	600	589	1067	533.5	840	1041	987	831	22.23	95	104.83	400	23.6	M30	M30	M24	M30	2141
M1LW/M1LZ PN 25	450	436	914	457	670	785	794	648.5	22.23	85	94.63	330	21.3	M30	M20	M20	M24	1098
	500	487	991	495.5	730	880	811.5	665.5	22.23	85	94.63	330	21.3	M30	M20	M20	M27	1438
	600	589	1143	571.5	845	1050	987	831	22.23	95	104.83	400	23.6	M30	M30	M24	M30	2219
M1MW/M1MZ PN 40	450	436	914	457	685	825	794	648.5	22.23	85	94.63	330	21.3	M30	M20	M20	M36	1210
	500	487	991	495.5	755	906	882	726	22.23	95	104.83	400	23.6	M30	M30	M24	M39	1652
	600	589	1143	571.5	890	1060	1090	885	31.75	120	133.75	460	23.6	M30	M30	M24	M39	2709

TYPE PN	NPS	DIMENSIONS (mm)												WEIGHT (kg)		
		A	A1	ØB	ØB1	E	K	M	ØO	P	S	T	U	V	M2	Q-M2
M2CW/M2CZ Class 150	10	533	267	405	514	562	472	12.70	55	60.60	230	90	M24	M14	325	360
	12	610	305	485	592	605	515	12.70	55	60.60	230	90	M24	M14	480	530
	14	686	343	535	665	741	607	19.05	75	83.15	330	120	M30	M20	635	710
	16	762	381	595	750	779	633	22.23	85	94.63	330	120	M30	M20	840	940
M2DW/M2DZ Class 300	10	568	284	445	580	562	472	12.70	55	60.60	230	90	M24	M14	330	370
	12	648	324	520	652	605	515	12.70	55	60.60	230	90	M24	M14	610	660
	14	762	381	585	700	741	607	19.05	75	83.15	330	120	M30	M20	800	870
	16	838	419	650	799	779	633	22.23	85	94.63	330	120	M30	M20	1015	1100

Type	DN	DIMENSIONS, mm															WEIGHT	
		ØD	A	A1	ØB	ØB1	E	K	M	ØO	P	S	T	U	V	W	C	kg
ASME 150	450	436	914	457	710	825	793,9	645,7	22,23	85	95,68	330	1235	M30	M20	M20	M27	1001
	500	487	991	495,5	775	906	881	725	22,23	85	105,87	330	1692	M30	M20	M20	M27	1304
	600	589	1143	571,5	915	1060	1090	885	31,75	95	136,54	400	2636	M30	M30	M24	M30	2087
ASME 300	450	436	864	389,5	635	800	793,9	645,7	22,23	85	95,68	330	21,3	M30	M20	M20	M36	1235
	500	487	914	457	700	885	811	665	22,23	95	95,68	400	23,6	M30	M30	M24	M39	1692
	600	589	1067	533,5	815	1041	987	831	22,23	120	105,87	460	23,6	M30	M30	M24	M39	2636

Type	NPS	DIMENSIONS, inch															WEIGHT	
		ØD	A	A1	ØB	ØB1	E	K	M	ØO	P	S	T	U	V	W	C	lbs
ASME 150	18	17.17	35.98	17.99	27.95	32.48	31.26	25.42	0.88	3.35	3.77	12.99	48.62	M30	M20	M20	M27	2224
	20	19.17	39.02	19.51	30.51	35.67	34.69	28.54	0.88	3.35	4.17	12.99	66.61	M30	M20	M20	M27	2898
	24	23.19	45.00	22.50	36.02	41.73	42.91	34.84	1.25	3.74	5.38	15.75	103.78	M30	M30	M24	M30	4638
ASME 300	18	17.17	34.02	15.33	25.00	31.50	31.26	25.42	0.88	3.35	3.77	12.99	0.84	M30	M20	M20	M36	2744
	20	19.17	35.98	17.99	27.56	34.84	31.93	26.18	0.88	3.74	3.77	15.75	0.93	M30	M30	M24	M39	3760
	24	23.19	42.01	21.00	32.09	40.98	38.86	32.72	0.88	4.72	4.17	18.11	0.93	M30	M30	M24	M39	5858

12.3 Topwork assembly dimensions

VALVE + B1C/B1J/B1JA

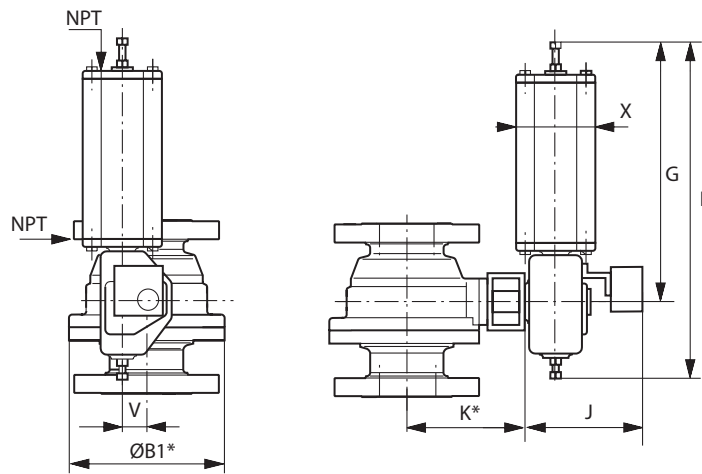

*) See K and ØB1 dimensions from tables on page 8 and 9.

B1C ACTUATOR

Actuator	DIMENSIONS, mm					NPT	kg
	F	G	J	V	X		
B1C6	400	260	283	36	90	1/4	4.2
B1C9	455	315	279	43	110	1/4	9.6
B1C11	540	375	290	51	135	3/8	16
B1C13	635	445	316	65	175	3/8	31
B1C17	770	545	351	78	215	1/2	54
B1C20	840	575	385	97	215	1/2	73
B1C25	1040	710	448	121	265	1/2	131
B1C32	1330	910	525	153	395	3/4	256
B1C40	1660	1150	595	194	505	3/4	446
B1C50	1970	1350	690	242	610	1	830

Actuator	DIMENSIONS, inch					NPT	lbs
	F	G	J	V	X		
B1C6	15.75	10.24	11.14	1.42	3.54	1/4	9
B1C9	17.91	12.40	10.98	1.69	4.33	1/4	21
B1C11	21.26	14.76	11.42	2.01	5.31	3/8	35
B1C13	25.00	17.52	12.44	2.56	6.89	3/8	68
B1C17	30.31	21.46	13.82	3.07	8.46	1/2	119
B1C20	33.07	22.64	15.16	3.82	8.46	1/2	161
B1C25	40.94	27.95	17.64	4.76	10.43	1/2	289
B1C32	52.36	35.83	20.67	6.02	15.55	3/4	564
B1C40	65.35	45.28	23.43	7.64	19.88	3/4	983
B1C50	77.56	53.15	27.17	9.53	24.02	1	1829

B1J/B1JA ACTUATOR

Actuator	DIMENSIONS, mm					NPT	kg
	F	G	J	V	X		
B1J/B1JA6	485	368	273	36	110	3/8	8
B1J/B1JA8	560	420	279	43	135	3/8	17
B1J/B1JA10	650	490	290	51	175	3/8	30
B1J/B1JA12	800	620	316	65	215	1/2	57
B1J/B1JA16	990	760	351	78	265	1/2	100
B1J/B1JA20	1200	935	358	97	395	3/4	175
B1J/B1JA25	1530	1200	448	121	505	3/4	350
B1J/B1JA32	1830	1410	525	153	540	1	671
B1J/B1JA40	2095	1578	580	194	724	1	1100

Actuator	DIMENSIONS, inch					NPT	lbs
	F	G	J	V	X		
B1J/B1JA6	19.09	14.49	10.75	1.42	4.33	3/8	20
B1J/B1JA8	22.05	16.54	10.98	1.69	5.31	3/8	37
B1J/B1JA10	25.59	19.29	11.42	2.01	6.89	3/8	66
B1J/B1JA12	31.50	24.41	12.44	2.56	8.46	1/2	126
B1J/B1JA16	38.98	29.92	13.82	3.07	10.43	1/2	220
B1J/B1JA20	47.24	36.81	14.09	3.82	15.55	3/4	386
B1J/B1JA25	60.24	47.24	17.64	4.76	19.88	3/4	771
B1J/B1JA32	72.05	55.51	20.67	6.02	21.26	1	1479
B1J/B1JA40	82.48	62.13	22.8	7.64	28.5	1	2424

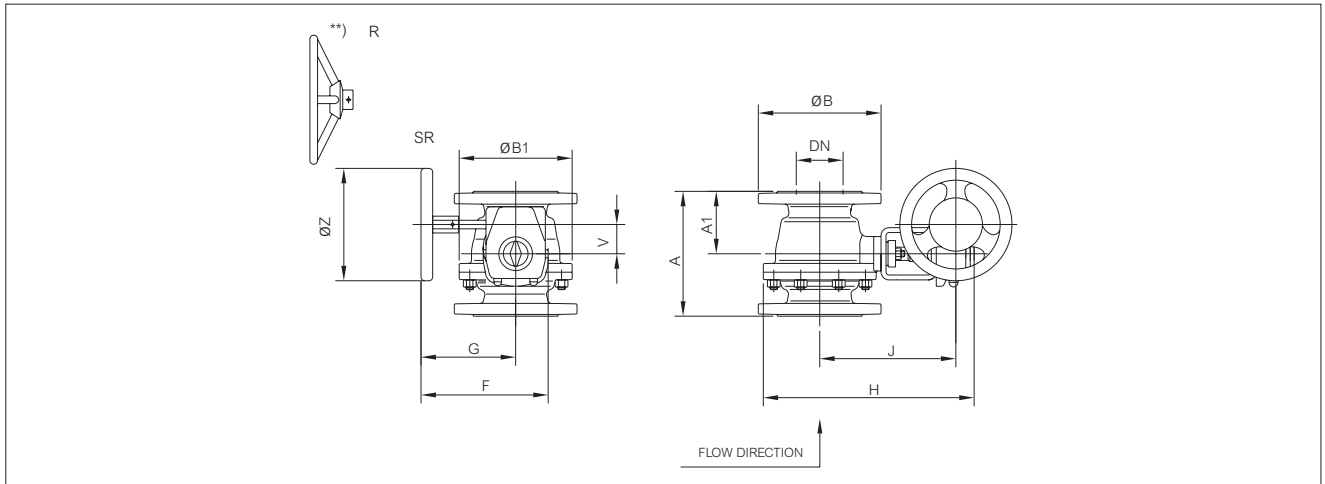

SEAT SUPPORTED VALVE M1 AND MANUAL GEAR OPERATOR SERIES M

DN	TYPE	ACTUATOR / MOUNTING	DIMENSIONS, mm										WEIGHT (kg)
			A	A1	ØB	ØB1	F	G	H	J	V	ØZ	
65	M1J, M1K	M07/25 / F07	270	135	185	154	235	184	320	205	52	160	23
80		M07/25 / F07	203	101.5	200	184	235	184	350	220	52	160	25
100		M12/35 / F12	229	114.5	220	236	307	238	455	292	71	315	45
100		M14/35 / F14	229	114.5	220	236	385	285	465	293	86	400	60
150		M14/45 / F14	394	197	285	338	385	285	570	348	86	400	120
150		M15/45 / F16	394	197	285	338	456	346	580	354	105	500	135
200		M15/55 / F16	457	228.5	340	426	456	346	700	434	105	500	195
200		M16/55 / F16	457	228.5	340	426	530	387	725	441	130	500	210
250		M16/65 / F25	533	266.5	405	512	530	387	855	528	130	500	340
300		M25/75 / F25	610	305	460	584	597	412	1010	615	182	600	510
200	M1L	M16/55 / F16	502	251	360	432	530	387	730	440	130	500	250
250		M16/65 / F25	568	284	425	512	530	387	855	528	182	600	355
300		M25/75 / F25	648	324	485	584	597	412	1010	615	182	600	540
25	M1J, M1K, M1L, M1M	M07/15 / F07	165	70	124	110	235	184	270	179	52	160	9
40		M07/20 / F07	165	74	155.5	149	235	184	307	197	52	160	12
50		M07/25 / F07	178	79	165	146	235	184	310	198	52	160	20
65	M1L, M1M	M07/25 / F07	270	135	185	154	235	184	320	205	52	160	23
80		M10/25 / F10	282	141	200	195	238	187	355	219	52	200	40
80		M12/25 / F12	282	141	200	195	307	238	380	232	71	315	45
100		M12/35 / F12	305	152.5	235	252	307	238	465	292	71	315	65
100		M14/35 / F14	305	152.5	235	252	385	285	470	293	86	400	75
150		M15/45 / F16	403	201.5	300	346	456	346	585	354	105	500	150

**) Actuators M07...M12 are equipped with handwheel type SR, P actuators M14...M25 are equipped with handwheel type R.
Face-to-face dimensions acc. to ISO 5752 ppressure ratings
J=PN10, K=PN16, L=PN25, M=PN40P flanged, full bore

SEAT SUPPORTED VALVE M2 AND MANUAL GEAR OPERATOR SERIES M

NPS	TYPE	ACTUATOR / MOUNTING	DIMENSIONS, mm										WEIGHT (kg)
			A	A1	ØB	ØB1	F	G	H	J	V	Øz	
1	M2C	M07/15 / F07	165	74	124	110	235	184	270	177	52	160	9
1.5		M07/20 / F07	165	70	155	145	235	184	305	195	52	160	13
2		M07/25 / F07	178	79.0	152.4	146	235	184	310	198	52	160	15
3		M07/25 / F07	203	101.5	190.5	190	235	184	350	220	52	160	29
4		M12/25 / F12	229	110.5	228.6	241	307	238	455	292	71	315	51
4		M14/45 / F14	394	197.0	279.5	342	385	285	570	348	86	400	120
6		M15/55 / F16	457	228.5	342.9	430	456	346	700	434	105	500	205
8		M16/65 / F25	533	266.5	406.4	512	530	387	855	527	130	500	330
12		M25/75 / F25	610	305.0	482.6	592	597	412	1015	615	182	600	520
1		M2D	M07/15 / F07	165	74.0	124.0	110	235	184	270	177	52	160
1.5	M07/20 / F07		191	70.0	155.0	145	235	184	305	195	52	160	16
2	M07/25 / F07		216	89.0	165.1	146	235	184	310	198	52	160	19
3	M07/25 / F07		282	141.0	209.6	200	235	184	350	220	52	160	40
4	M12/25 / F12		305	152.5	254.0	254	307	238	455	292	71	315	70
6	M14/45 / F14		403	201.5	317.5	353	385	285	570	348	86	400	155
8	M15/55 / F16		419	209.5	381.0	462	456	346	700	434	105	500	265
10	M16/65 / F25		457	208.0	445.5	552	530	387	875	527	130	500	400
12	M25/75 / F25		502	223.0	520.7	626	597	412	1030	615	182	600	605

TRUNNION TYPE VALVE M1 AND MANUAL GEAR OPERATOR SERIES M

DN	TYPE	ACTUATOR / MOUNTING	DIMENSIONS, mm										WEIGHT (kg)
			A	A1	ØB	ØB1	F	G	H	J	V	ØZ	
250	M1JW/M1JZ	M15/55 / F16	533	267	395	514	456	346	880	520	105	500	335
300		M16/55 / F16	610	305	445	592	530	387	990	570	130	500	500
350	M1KW/M1KZ	M25/75 / F25	686	343	520	665	597	412	1160	665	182	600	740
400		M25/85 / F25	762	381	580	750	597	412	1225	690	182	600	950
250	M1LW/M1LZ	M15/55 / F16	568	284	425	580	456	346	910	520	105	500	350
300		M16/55 / F16	648	324	485	652	530	387	1020	570	130	500	515
350		M25/75 / F25	762	381	555	700	597	412	1175	665	182	600	800
400	M1MW/M1MZ	M25/85 / F25	838	419	620	799	597	412	1250	690	182	600	1030
250		M15/55 / F16	568	284	450	580	456	346	910	520	105	500	505
300		M16/55 / F16	648	324	515	652	530	387	1020	570	130	500	650
350		M25/75 / F25	762	381	580	700	597	412	1175	665	182	600	920
400		M25/85 / F25	838	419	660	799	597	412	1250	690	182	600	1250

Face-to-face dimensions acc. to ISO 5752
Pressure ratings J=PN10, K=PN16, L=PN25, M=PN40
Flanged, full bore
Face-to-face dimensions acc. to ASME B16.10
Pressure ratings C=ASME 150, D=ASME 300
Flanged, full bore

TRUNNION TYPE VALVE M2 AND MANUAL GEAR OPERATOR SERIES M

NPS	TYPE	ACTUATOR/ MOUNTING	DIMENSIONS, mm										WEIGHT (kg)
			A	A1	ØB	ØB1	F	G	H	J	V	Øz	
10	M2CW/M2CZ	M15/55 / F16	533	267	405	514	456	346	815	520	105	500	335
12		M16/55 / F16	610	305	485	592	530	387	965	570	130	500	500
14		M25/75 / F25	686	343	535	665	597	412	1150	670	182	600	740
16		M25/85 / F25	762	381	595	750	597	412	1120	700	182	610	950
10	M2DW/M2DZ	M15/55 / F16	568	284	445	552	456	346	835	520	105	500	505
12		M16/55 / F16	648	324	520	626	530	387	980	570	130	500	650
14		M25/75 / F25	762	381	585	700	597	412	1160	670	182	600	920
16		M25/85 / F25	838	419	650	800	597	412	1240	700	182	610	1250

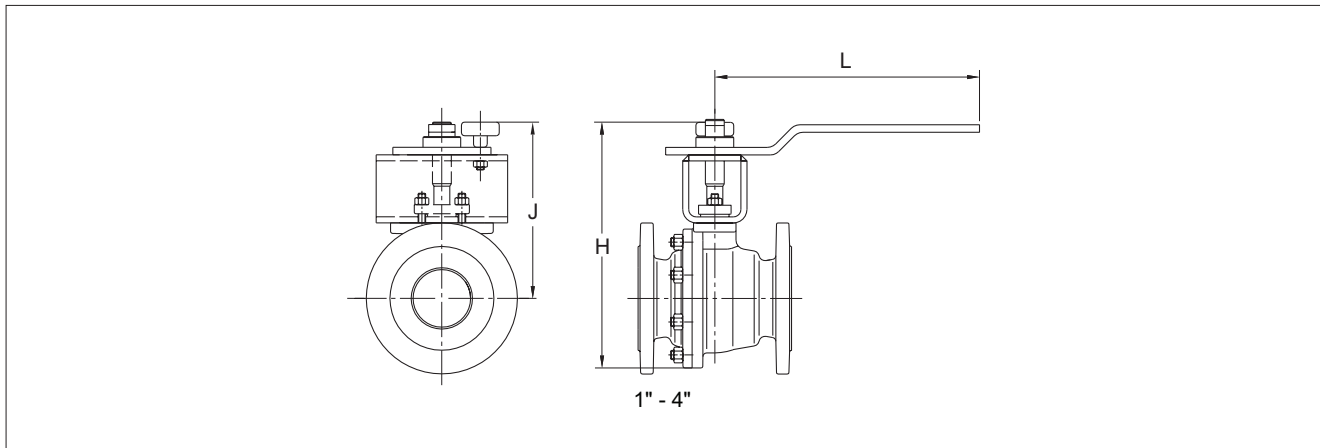

SEAT SUPPORTED VALVE M1 AND HAND LEVER LX/LK

DN	TYPE	HAND LEVER	DIMENSIONS, mm			WEIGHT (kg)
			H	J	L	
25	M1M, M1L, M1K, M1J	LX180A	263	201	140	6
40		LX220A	304	227	170	9
50		LK350	295	222	350	14
65	M1M, M1L	LK350	305	230	350	21
80		LK350	342	244	350	35
100		LK450	435	309	450	55
65	M1K, M1J	LK350	305	230	350	21
80		LK350	336	244	350	25
100		LK450	427	309	450	40

SEAT SUPPORTED VALVE M2 AND HAND LEVER LX / LK

NPS	TYPE	HAND LEVER	DIMENSIONS, mm			WEIGHT (kg)
			H	J	L	
1	M2C	LX180A	263	201	140	6
1.5		LX220A	304	227	170	10
2		LK350	300	222	350	15
3		LK350	340	244	350	30
4		LK450	430	309	450	45
1	M2D	LX180A	263	201	140	9
1.5		LX220A	304	227	170	13
2		LK350	305	222	350	20
3		LK350	350	244	350	40
4		LK450	435	309	450	65

13. TYPE CODE

Neles™ modular ball valve, series M1 and M2										
1.	2.	3.	4.	5.	6.	7.	8.	9.		10.
	M1	M	A	150	A	P	V	A	/	-

1. sign	Low noise construction
Q-	Attenuator in flow port of ball

2. sign	Valve series, face-to-face length
M1	Full bore, seat supported, f-to-f length acc. to ISO 5752 basic series 3, 4, 12 or 15 depending on size and pressure class. Seat supported DN 025-300, trunnion mounted DN 250-600.
M2	Full bore, seat supported, f-to-f length acc. to ASME B16.10
M9	Face-to-Face acc. to P-series. Seat supported types for sizes: DN 100, 150, 200, 250 and 300. Trunnion mounted types for sizes: DN 350 and 600.

3. sign	Pressure rating of body and flanges
J	EN PN 10
K	EN PN 16
L	EN PN 25
M	EN PN 40
R	JIS 10K
S	JIS 16K
T	JIS 20K
C	ASME Class 150
D	ASME Class 300

4. sign	Construction
A	Standard construction, seat supported
W	Trunnion mounted, 2-seats
Z	Trunnion mounted, 1-seat *
P	Pocket Feeder (only sizes DN150 and DN200mm, EN PN10 and EN PN16)

5. sign	Size
Seat supported valves	025, 040, 050, 065, 080, 100, 125, 150, 200, 250, 300 (M1) 01, 1H, 02, 03, 04, 06, 08**, 10**, 12** (M2)
Trunnion mounted valves	250, 300, 350, 400, 450, 500, 600 (M1) 10, 12, 14, 16, 18, 20, 24 (M2)

6. sign	MATERIALS			
	Body material	Trim (and Coating) material	Stem material	Bolting material / thread
A	CF8M	CF8M (+ Hard Chrome, if metal seat)	AISI 329 trunnion mounted: XM-19 (DN250-600, 10"-24")	A2-70 (M1) B8M/8M (M2) /metric
C	CG8M	CG8M (+ Hard Chrome, if metal seat)	AISI 329 trunnion mounted: XM-19 (DN250-600, 10"-24")	A2-70 (M1) B8M/8M (M2) /metric
U	CK-3MCuN	CK-3MCuN (& Ceramic coating, if metal seat)	UNS S31254	A2-70 (M1) B8M/8M (M2) /metric
S*	CF8M + Cobalt based alloy sleeves in flow ports	CF8M (cobalt based coating on ball surface and flow port)	AISI 329 Only for Seat supported type	A2-70 (M1) B8M/8M (M2) /metric
X**	4A	4A (+ Hard Chrome, if metal seat)	AISI 329 trunnion mounted: XM-19 (DN250-600, 10"-24")	A2-70 (M1) B8M/8M (M2) /metric
Specials for POCKET FEEDER valves				
G (DN150,200)	G (DN150,200)	CF8M UNS S31803 & Tungsten chrome carbide (W/Cr)C	XM-19	A2-70 (M1) B8M/8M (M2) /metric

* Material code "S", only for SEAT SUPPORTED types.

** Intended for erosive (black liquor) evaporation service with metal seats (V).

7. sign	MATERIALS			
	Seat type	Seat material	Bearing material	Back seal material
SEAT SUPPORTED (*				
P	locked	SS + Cobalt based hard facing	PTFE + Graphite	PTFE
X	soft	Xtreme®	PTFE + Graphite	-
T	soft	PTFE	PTFE + Graphite	-
S	unlocked	SS + Cobalt based hard facing	PTFE + Graphite	PTFE
E	low Dp	SS + Cobalt based hard facing	PTFE + Graphite	PTFE/FPM
C	locked	CK-3MCuN + Cobalt based hard facing	PTFE + Graphite	PTFE
V	locked	4A + Cobalt based hard facing	PTFE + Graphite	PTFE
M	soft	Filled PTFE	PTFE + Graphite	-
A (DN050,080)	locked/forced	UNS S31803 + Cobalt based hard facing	PTFE + Graphite	Graphite and EPDM
B (DN150,200)	locked/forced	UNS S31803 + Tungsten chrome carbide (W/Cr)C	Cobalt based alloy and SS steel	Graphite and Viton
TRUNNION MOUNTED				
S	metal	SS + Cobalt based hard facing	PTFE + Graphite	Viton GF
P	metal	SS + Cobalt based hard facing	PTFE + Graphite	FFKM
T	soft	PTFE + C25	PTFE + Graphite	-

Note: Sizes DN 25mm and 40mm, all bearing material PTFE

8. sign	Packing	Body gasket
V	PTFE V-rings,	PTFE
F	Graphite	Graphite
M	Modified PTFE V-ring (*	PTFE
G	Live loaded graphite packing	Graphite
T	Live loaded PTFE packing for	PTFE

(* for high cycle applications in liquor service having tendency for built-up and mechanical packing wear.

9. sign	Model code
A	Version

10. sign	End connection style
Standard, without sign	EN 1092-1 Type B1 (Ra 3.2 - 12.5), standard, without sign (M1) ASME B16.5 0.06" raised face with Ra 3.2 - 6.3 µm, Ra 125 - 250 µin (M2)
12	ASME B16.5 Large male (M2)
13	ASME B16.5 Large female (M2)
23	EN 1092-1 Type C Tongue (M1)
24	EN 1092-1 Type D Groove (M1)
25	EN 1092-1 Type E Spigot (M1)
26	EN 1092-1 Type F Recess (M1)

*) flow direction indicated by an arrow on the body

** Class 300 body f-to-f acc. to ASME B16.10, table 2, short pattern

Note: M2-series.

Seat supported, NPS 01"-06", cl. 150/300, acc. to B16.10, long pattern
 Seat supported, NPS 08"-12", cl. 150, acc. to B16.10, table 1, long pattern
 Seat supported, NPS 08"-12", cl. 300, acc. to B16.10, table 2, short pattern
 Trunnion mounted, NPS 10"-16", cl. 150/300, acc. to B16.10 long pattern

Valmet Flow Control Oy

Vanha Porvoontie 229, 01380 Vantaa, Finland.

Tel. +358 10 417 5000.

www.valmet.com/flowcontrol

Subject to change without prior notice.

Neles, Neles Easyflow, Jamesbury, Stonel, Valvcon and Flowrox, and certain other trademarks, are either registered trademarks or trademarks of Valmet Oyj or its subsidiaries in the United States and/or in other countries.

For more information www.neles.com/trademarks

